

Wide view mast VM

Mast model	Load center 500mm			Max.lift height	Mast height			Tilt angle fwd-bwd	(3) Weight		
	XCB-GD 30	XCB-GD 35	XCB-D 40		fork lowered		(1)fork lift with backrest		XCB-G 30	XCB-G 35	XCB-D 40
					XCB-GD 30 35	XCB-D 40					
kg	kg	kg	mm	mm	mm	mm	deg	kg	kg	kg	
VM250	3000	3500	4000	2500	1825	1900	3750	6 - 12	4270	4650	5000
VM270	3000	3500	4000	2700	1925	2000	3950	6 - 12	4285	4670	5020
VM300	3000	3500	4000	3000	2075	2150	4250	6 - 12	4300	4700	5050
VM330	3000	3500	4000	3300	2225	2300	4550	6 - 12	4335	4730	5080
VM350	3000	3500	4000	3500	2325	2400	4750	6 - 12	4350	4750	5100
VM400	3000	3500	4000	4000	2625	2700	5250	6 - 6 * 6 - 12	4430	4835	5185
VM450	2900 * 3000	3000 * 3500	3400 * 4000	4500	2875	2950	5750	6 - 6 * 6 - 12	4470	4780	5225
VM500	2700 * 2850	2800 * 3300	3200 * 3700	5000	3125	3200	6250	6 - 6 * 6 - 6	4515	4930	5300
VM550	* 2400	* 2700	* 3100	5500	3425	3500	6750	* 3 - 6	4740	5160	5495
VM600	* 2000	* 2300	* 2700	6000	3675	3750	7250	* 3 - 6	4780	5205	5535

2 Stage free lift mast VFM

Mast model	Load center 500mm			Max.lift height	Mast height			(2)free lift with backrest	Tilt angle fwd-bwd	(3) Weight		
	XCB-GD 30	XCB-GD 35	XCB-D 40		fork lowered		(1)fork lift with backrest			XCB-G 30	XCB-G 35	XCB-D 40
					XCB-GD 30 35	XCB-D 40						
kg	kg	kg	mm	mm	mm	mm	deg	kg	kg	kg		
VFM250	3000	3500	4000	2500	1825	1875	3760	600	6 - 12	4330	4720	4970
VFM270	3000	3500	4000	2700	1925	1975	3960	700	6 - 12	4350	4740	4990
VFM300	3000	3500	4000	3000	2075	2125	4260	850	6 - 12	4380	4770	5020
VFM330	3000	3500	4000	3300	2225	2275	4560	1000	6 - 12	4405	4795	5045
VFM350	3000	3500	4000	3500	2325	2375	4760	1100	6 - 12	4425	4815	5065

3 Stage free lift mast VFHM

Mast model	Load center 500mm			Max.lift height	Mast height			(2)free lift with backrest	Tilt angle fwd-bwd	(3) Weight		
	XCB-GD 30	XCB-GD 35	XCB-D 40		fork lowered		(1)fork lift with backrest			XCB-G 30	XCB-G 35	XCB-D 40
					XCB-GD 30 35	XCB-D 40						
kg	kg	kg	mm	mm	mm	mm	deg	kg	kg	kg		
VFHM360	3000	3500	4000	3600	1825	1825	4860	600	6 - 6 * 6-10	4490	4880	5130
VFHM400	3000	3500	4000	4000	1950	1950	5260	725	6 - 6 * 6-10	4525	4915	5165
VFHM435	2900 * 3000	3200 * 3500	3650 * 4000	4350	2075	2075	5660	850	6 - 6 * 6-10	4560	4950	5200
VFHM450	2850 * 3000	3100 * 3500	3540 * 4000	4500	2150	2150	5760	925	6 - 6 * 6-10	4575	4970	5225
VFHM480	2800 * 2900	2900 * 3400	3310 * 3880	4800	2225	2225	6060	1000	6 - 6 * 6-10	4595	4985	5235
VFHM500	2600 * 2700	2800 * 3100	3200 * 3540	5000	2325	2325	6260	1100	6 - 6 * 6 - 10	4625	5015	5265
VFHM550	1900 * 2650	2000 * 2700	2280 * 3085	5500	2460	2460	6760	1250	3 - 6 * 6 - 6	4675	5050	5300
VFHM600	1400 * 2100	1500 * 2300	1700 * 2630	6000	2675	2675	7260	1450	3 - 6 * 3 - 6	4750	5140	5390
VFHM650	* 1700	* 1700	* 1940	* 6500	2890	2890	7760	1665	* 3 - 3	4965	5350	5600
VFHM700	* 1350	* 1350	* 1540	* 7000	3110	3110	8260	1885	* 3 - 3	5020	5410	5660

Notes: (1) Max. Lift height (without backrest): -580mm (2) Free lift height without backrest: +580mm; Weight without backrest: -30kg (3) Diesel forklift weight: +80kg

Notes: The mark of * is with double tires, the weight with double tires: +150kg

Lift speed with VFM/VFHM VFM/XCB-G400mm/s full load, 450mm/s no load; XCB-D400mm/s/full load, 420mm/s/no load

VFHM: XCB-G410mm/s full load, 470mm/s no load; XCB-D420mm/s/full load, 440mm/s no load.

Lowering speed: VFM/VFHM 400mm/s full load, 300mm/s no load.



Distributor



XCB-D/DT30-35-40

Internal Combustion Diesel Forklift



Three Features



1 Cleaner, more efficient Engines

New engines, compliant with worldwide stage III A emission regulations (ISUZU C240PKJ, Mitsubishi S4S Diesel powered engine).

2 Easy Maintenance

Detachable side covers and a wide-opening hood for convenient inspection and simple maintenance. Integral layout of electrical parts and other system devices.



3 Easier entry and exit from an extra-wide step

The secure step with enlarged foot space enables greater comfort and less fatigue while entering and exiting the vehicle.



■ Main Truck Specifications

Features	1	Manufacturer	XCMG							
	2	Model	Power shift	XCB-DT30		XCB-DT35		XCB-DT40		
			Manual shift	XCB-D30		XCB-D35		XCB-D40		
3	Load capacity		kg	3000		3000		4000		
4	Load center		mm	500				500		
5	Power unit			Diesel				Diesel		
6	Operator type			Driver/seat				Driver/seat		
7	Tire type			Pneumatic				Pneumatic		
8	Wheel	Front/rear		2/2				2/2		
Dimension	9	Max. lifting height	mm	3000				3000		
	10	Free lift	mm	150				150		
	11	Fork size	L*W*T	mm	1070*125*45		1070*125*50		1070*150*50	
	12	Tilt range	Mast forward/backward	deg	6/12				6/12	
	13	Overall length(without fork)		mm	2705		2760		2870	
	14	Total width		mm	1225		1285		1365	
	15	Mast height (fork lowering)		mm	2075				2150	
	16	Overall height fork raised	With backrest	mm	4250				4250	
	17	Height to head guard		mm	2140				2140	
	18	Turning radius(outside)		mm	2445		2495		2530	
	19	Front face of fork to front axle		mm	480		485		485	
20	Min. right angle stacking aisle (without load length&clearance)		mm	2925		2975		2940		
Performance	21	Speed	Max Travelling (full/no load)	km/h	18/19.5			16.5/18		
	Lifting (full/no load)		mm/s	450/500			380/480			
	23	Lowering (full/no load)	mm/s	450/450		450/420		450/420		
	24	Max.drawbar pull	Power shift (full/no load)	kg	1500/1000		2200/1000		2200/1000	
			Manual shift (full/no load)	kg	1550/1000		2200/1000		2200/1000	
25	Gradeability at 1.6km/h	Power shift (full/no load)	%	18/20			18/20			
		Manual shift (full/no load)	%	18/20			18/20			
Weight	26	Truck weight	kg	4380		4780		5050		
	27	Weight distribution	Full load (front/rear)	kg	6490/890		7380/900		7890/1140	
			No load (front/rear)	kg	1670/2700		1820/2960		1810/3240	
Frame	29	Tires	Number	front/rear	2/2			2/2		
	Model		front axle	28x9-15-12PR			250-15-16PR			
	Model		rear axle	6.50-10-10PR			6.50-10-10PR			
	32	Wheelbase	mm	1700				1800		
	33	Tread	Front/rear	mm	1000/970		1060/970		1120/970	
			At lowest point(mast)	mm	120				120	
34	Ground clearance	Frame	mm	135				135		
		Service brake		Hydraulic-foot pedal			Hydraulic-foot pedal			
		Parking brake		Mechanical-hand lever			Mechanical-hand lever			
Engine	36	Battery	Voltage/capacity	V/AH	12/80			12/80		
	37	Engine	Model		XINCHAI 4D27G31	mitsubishi S4S	ISUZU C240	XINCHAI 4D30G31	mitsubishi S4S	ISUZU 4JG2
			Rated power	kw/rpm	36.8/2500		35.3/2250		35.4/2500	
			Rated torque	N.m/rpm	156/1700-1900		170/1700		139.9/1800	
			Number of cylinders		4		4		4	
			Placement	L	2.67		3.331		2.369	
	38	Fuel tank capacity		L	70				70	
	39	Transmission	Speed forward/backward	Power shift	1-1 power shift			1-1 power shift		
Manual shift				2-2 manual shift			2-2 manual shift			
40	Operating pressure	Hydraulic system pressure	kg/cm ²	180				180		

Note: There's also Yanmar 4TNE98, Chinese Xinchai C495 diesel engine for option, and the specs will be little different.

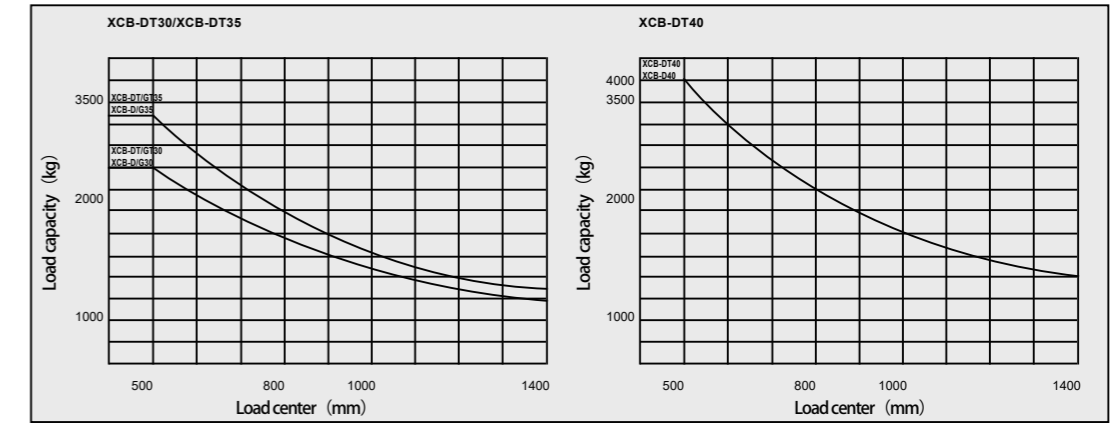

Notes:

Vertical axis represents load capacity; Horizontal axis shows load center, Load center are determined from front face of the fork. Capacity based on a 1000mm cube load configuration with the center of gravity at the true center of the cube, and standard fork. The load capacity will be reduced while the mast tilt forward or loading with long fork or lifting transformable width of goods. Getting the load capacities at the various load centers timely via the load curve.

XCMG's products and specifications change without prior notice.

XCMG forklift truck has equipped with standard safety device.

XCMG is not responsible for the damage occurred by removing its safety device.

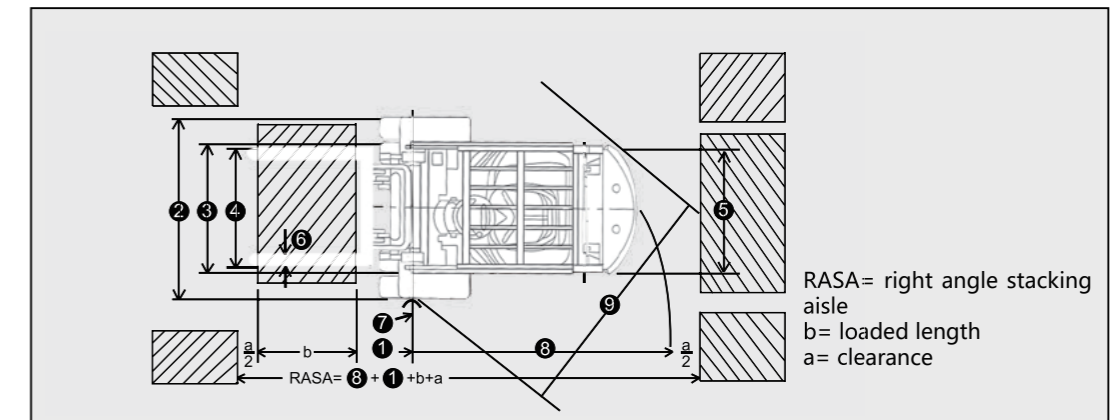

Specifications(front single tires)

Model	XCB-G/D30、XCB-GT/DT30	XCB-G/D35、XCB-GT/DT35	XCB-D40、XCB-DT40
	(mm)	(mm)	(mm)
① Front Overhang	480	485	485
② Total Width	1225	1285	1365
③ Front Track	1000	1060	1120
④ Fork Spread(outside)	250~1090	250~1190	250~1190
⑤ Rear Track	970	970	970
⑥ Fork Width	125	125	150
⑦ Turning Radius(inside)	200	200	200
⑧ Turning Radius(outside)	2445	2495	2530
⑨ Right Angle Turning Aisle	2155	2205	2450

Standard equipments:

Wide view mast, Cyclone air cleaner, Load one-way valve, Preheat indicator, King Pin, Engin-start switch, Standard backrest, Long-life tires, Overhead guard, Oil and water separator, Power steering, Adjustable steering column, Radiator water tank, Side roller, Standard carriage, Oil temperature cooler, Headlamp and steering indicator lamp, Charge indicator lamp, Hour meter, Oil warning light of engin, Water temperature gauge, Fuel gauge, Reversing light, Electric horn, Neutral-safety switch, Rear mirror, Tools, Reversing Buzzer, General seat.

Options:

Fire extinguisher, cab, Heater unit, Rear work light, Solid tires, Fireproof silencer, Upper exhaust pipe, Tilt cylinder jacket, Rotating warning light, LPG Conversion device, Pre-filtration air intake device.

Attachments:

Side shifter, Fork positioned, Carpet boom, Fork extension, Long fork flat clamp, Others