

**XCMG**  
**徐工集团**  
徐工徐工 助您成功  
XCMG FOR YOUR SUCCESS



**HANVAN 漢風 G7**

**6 × 4 左驾牵引车 NXG4252D5WC**

**HANVAN G7 6 × 4 LHD TRACTOR**

 **徐州徐工汽车制造有限公司**  
XUZHOU XCMG AUTO MANUFACTURING CO.,LTD.

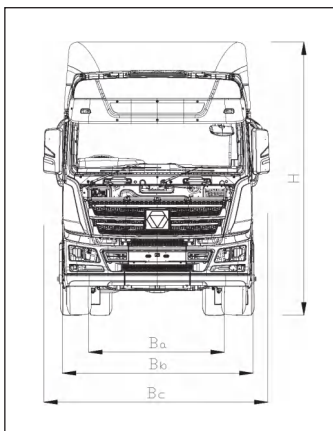
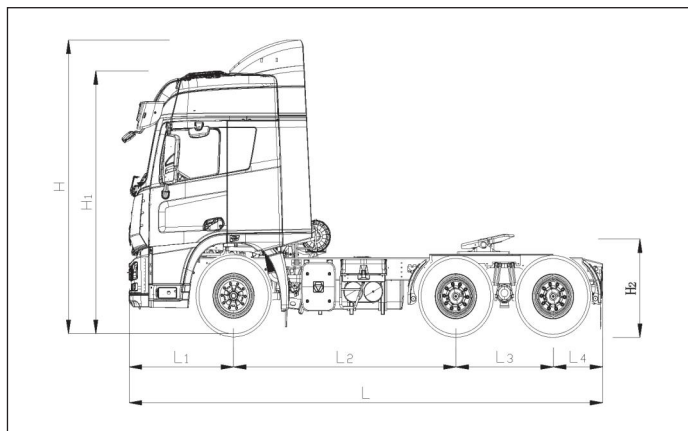
**外形尺寸/Appearance size**

L1 前悬/Front overhang	1500mm
L2 第一、二轴轴距/First and second wheel base	3300mm
L3 第二、三轴轴距/Second and third wheel base	1350mm
L4 后悬/Rear overhang	710mm
L 最大长度/Max length	6810mm
H1 驾驶室高度/Cab height	3600mm
H2 牵引座离地高度/Height of traction base	1270mm
H 最大高度/Max height	3970mm
Ba 轮距/Wheel tread	3048mm
Bb 整车宽度/Overall width	2550mm
Bc 最大宽度/Max width	2970mm

## 主要参数 / Main Specifications

项目 Items	参数 Parameters
<b>性能参数/PERFORMANCE PARAMETERS</b>	
驱动形式/Drive Type	6 × 4
整备质量/Kerb Mass	11000kg
最大牵引总质量/Maximum total traction mass	90000kg (带挂车/Trailer)
最高车速/Max. Speed	70km/h (满载/Fully loaded)
最小转弯直径/Min. Turning Diameter	17m
最大爬坡度/Grade Ability	≥30%
油箱容积/Fuel Tank	750L
<b>尺寸参数/DIMENSIONS</b>	
外形尺寸/Dimension (mm)	6810 × 2550 × 3600/3970
轴距/Wheelbase (mm)	3200+1400
最小离地间隙/Min. Clearance	285mm
接近角/Approach Angle	18°
离去角/Departure Angle	46°
前悬/Front Overhang	1500mm
后悬/Rear Overhang	710mm
<b>驾驶室/CABIN</b>	
型号/Model	G7LH
左右驾/Left/Right Driving	左驾/LHD
空调/AC	选配/Optional
乘员人数/Person Allowed in	2, 3
<b>发动机/ENGINE</b>	
型号/Model	WP12.460E50/WP13.550E501
排放等级/Emission Standard	EURV
总排量/Displacement	11.596/12.54L
额定功率/Output Power	338/404KW
最大扭矩/Max Torque Speed	2110/2550N · m

项目 Items	参数 Parameters	
<b>离合器/CLUTCH</b>		
型号/Model	Φ430拉式膜片弹簧离合器 / Φ430 Pull type diaphragm spring clutch	
操纵方式/Manipulating	液压操纵气助力/Hydraulic manual	
<b>变速箱/TRANSMISSION</b>		
型号/Model	12JSDX220T-B(TA-B)/16JSDX240T(TA)	
取力器/PTO	选配/Optional	
前进档速比/Forward Ratio	13.15-1,12.1-0.78/16.69-1,13.75-1	
倒档速比/Reverse Ratio	12.58,11.57/15.97,13.15	
<b>车桥/AXLE</b>		
前桥型号/Front Axle Model	7.5T	
后桥型号/Rear Axle Model	16T	
主减速器速比/Main Reducer Ratio	4.769/5.262	
<b>轮胎/TIRE</b>		
轮辋/Rim	22.5 × 9.00	
轮胎/Tire	12.00R20	
<b>车架/FRAME</b>		
大梁截面/Girder section	300 × 80 × (8 + 8)	
车架总成宽度/Frame Width	865mm	
<b>悬架/SUSPENSION</b>		
前/Front	型式/Type	多片簧/Multi leaf spring
	板簧片数/Leaf springs	9
后/Rear	型式/Type	多片簧/Multi leaf spring
	板簧片数/Leaf springs	12
<b>制动/BRAKE</b>		
类型/Type	双回路气压制动/Double circuit air brake	
ABS	选配/Optional	