

XCT25L5_2 汽车起重机 / Truck Crane

技术规格书

Technical specifications

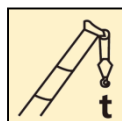

25 t

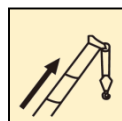

44 m

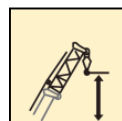

52 m



2021年5月 第3版

目录

Contents

目录 Contents	
尺寸参数 Dimensions	4
技术规格 Technical specifications	5-8
车型与选装件 Version and optional equipment	9
重量/作业速度 Weight / Working speeds	10
臂架组合方案 Boom / Jib combinations	11
主臂 Boom	12-14
副臂 Jib	15-16
注意事项 Notes	17
符号标识 Description of symbols	18
主要技术参数表 Table of main technical parameters	19-20

尺寸参数 Dimensions

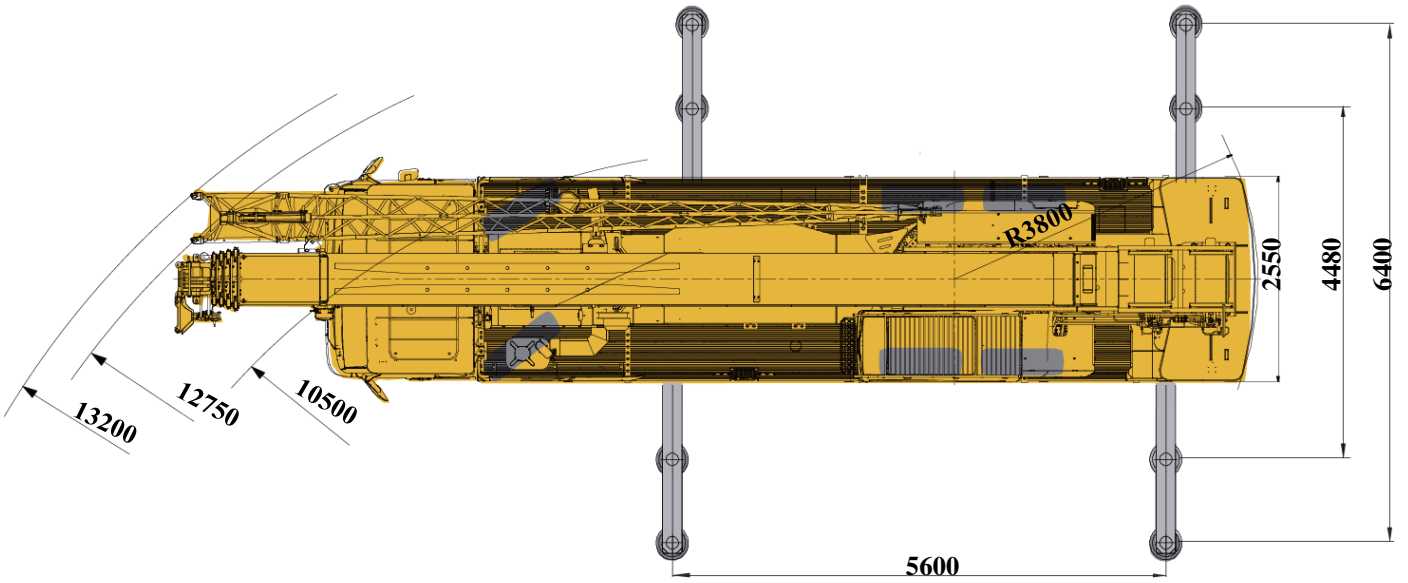
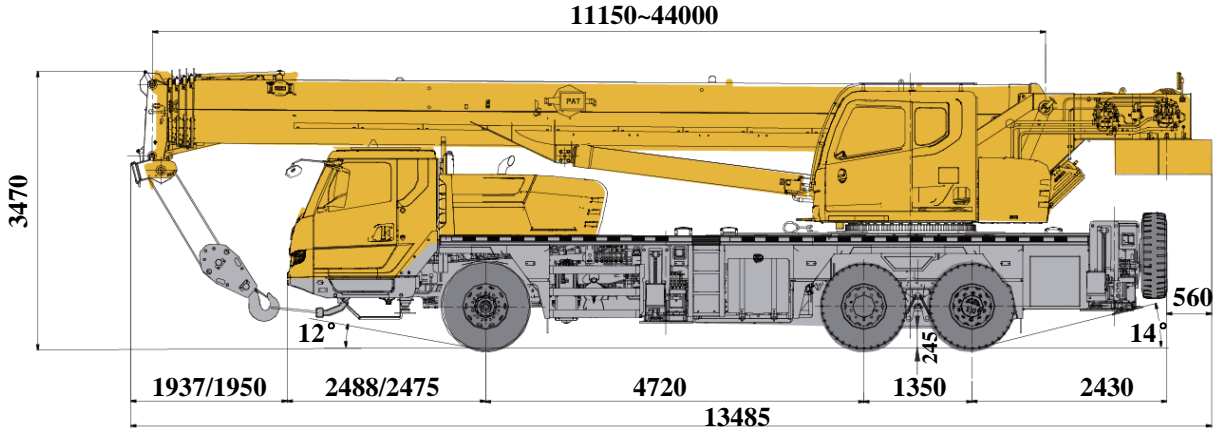

技术规格

Technical specifications



底盘

车架	徐工设计、制造，全覆盖式走台板，防扭转箱型结构，高强度钢材制造。
支腿	4支腿；纵向H形布置，操作杆控制液压动作；可由底盘任一侧同时或单独控制各支腿的动作，设有水平仪；带第五支腿；且垂直支腿带有液压双向锁。 支脚盘尺寸：φ400mm 最大起重量时支腿反力：323KN
发动机	SC9DF320Q5，直列六缸水冷电控柴油发动机，上柴，额定功率235kW/1900rpm，最大扭矩1350Nm/1100~1400rpm，最大基准扭矩：1400N.m；国五排放标准。 燃油箱容积：300L；尿素箱容积：35L。 MC07H.32-50，直列六缸水冷电控柴油发动机，重汽曼，额定功率235kW/2200rpm，最大扭矩1250Nm/1200~1600rpm，最大基准扭矩：1600N.m；国五排放标准。 燃油箱容积：300L；尿素箱容积：35L。 SC9DF320Q6，直列六缸水冷电控柴油发动机，上柴，额定功率235kW/1900rpm，最大扭矩1500Nm/1200~1500rpm，最大基准扭矩：1557N.m；国六排放标准。 燃油箱容积：300L/350L；尿素箱容积：35L。 MC07H.33-60，直列六缸水冷电控柴油发动机，重汽曼，额定功率240kW/2200rpm，最大扭矩1412Nm/1200~1600rpm，最大基准扭矩：1600N.m；国六排放标准。 燃油箱容积：300L/350L；尿素箱容积：35L。
变速箱	法士特9档变速箱，机械操纵，带同步器。 大同齿轮9档变速箱，机械操纵，带同步器。
车桥	配置美驰、汉德高强度车桥，2,3桥驱动。
悬挂	前悬架：纵置钢板弹簧，筒式减震器； 后悬架：橡胶悬架，重量轻，免维护。
轮胎	10个轮胎，1个备胎，前桥装单胎，中桥、后桥装双胎。 轮胎规格：315/80R22.5-18PR



底盘

制动	行车制动：双回路气压制动，作用于所有车轮。 驻车制动：弹簧贮能制动，作用于2-3轴车轮。 辅助制动：发动机排气制动和缓速制动
转向	机械式转向机构，带有液压助力
驾驶室	全宽驾驶室，乘员3人；配置收放机、可调式座椅、简易卧铺、方向盘、安全玻璃、3只雨刷器、电动后视镜、电动门窗升降器、杂物箱、空调
电气系统	直流24伏特，串联12伏特的电池组2个。 发电机 28伏特-70安培。

技术规格

Technical specifications



上车

结构	徐工设计、制造，高强度钢材制造。
液压系统	底盘发动机驱动变量柱塞泵，用于起升、变幅、伸缩。负载敏感式比例多路换向阀，带有抗冲击阀、防气蚀阀；风冷式液压油散热器；
操纵方式	液控先导操纵系统，由左右2个操纵手柄控制，由液压泵和比例阀进行液压先导式控制起重机的全部动作
主起升机构	液压控制调速，装有双折线绳槽卷筒，由液压马达通过行星齿轮减速器驱动，内置常闭式制动器并带有平衡阀；
副起升机构	液压控制调速，装有双折线绳槽卷筒，由液压马达通过行星齿轮减速器驱动，内置常闭式制动器并带有平衡阀；
回转机构	四点接触球式回转支承，由液压马达驱动行星齿轮回转机构减速器驱动，可连续回转360°；具有动力控制或自由回转的功能，可无级调速；回转杆设有鸣响开关；
变幅机构	单支双作用前置液压变幅油缸，带有平衡阀
操纵室	新型钢制操纵室，装有无视野死角的前景窗，安全玻璃，车窗装有遮阳板，推拉式车门，座椅靠背可倾斜定位，操纵杆安装在座椅两侧的扶手台上；带推拉踏板；前窗顶窗装有雨刮器；标配冷暖空调；
安全装置	液压平衡阀；液压溢流阀；液压双向锁；力矩限制器；三圈保护器，防止钢丝绳过放；臂头设置高度限位，防止钢丝绳过卷；三色报警灯；





臂架系统

主臂	5节，“U”形截面的筒形焊接结构。双缸绳排伸缩机构 主臂长度：11.2m ~ 44m。
臂端单滑轮	单滑轮，安装在主臂顶端用于单股钢丝绳起重作业，起重性能与9m副臂 0°安装角时的起重性能，但最大起重量不超过3t
固定副臂	1节桁架式焊接结构，具有0°、15°、30°三种固定副臂安装角 固定副臂长度：9m

技术规格

Technical specifications

 Chassis	
Frame	Designed and manufactured by XCMG, it is made of high strength steel with fully covered walking surface and anti-torsion box-typed structure.
Outriggers	Four outriggers arranged in H-shape are hydraulically controlled by control levers. There is an outrigger control station located at each side of the chassis, and there is a level gauge on each control station. The outrigger movements can be simultaneously or separately controlled at any side of the chassis. A fifth jack is available. Each jack cylinder is equipped with a double-way hydraulic valve. Outrigger float diameter: $\phi 400$ mm Reaction force of outrigger at max. lifting load: 323 KN
Engine	SC9DF320Q5, in-line, 6-cylinder, water cooled, electric control diesel engine, made by Shanghai Diesel Engine, with rated power of 235kW/1900rpm and max. torque of 1350Nm/1100~1400rpm, Max.reference torque: 1400 N.m compliant with China V emission standard. Fuel tank capacity: 300 L. AdBlue tank volume: 35L. MC07H.32-50, in-line, 6-cylinder, water cooled, electric control diesel engine, made by SINOTRUK MAN, with rated power of 235kW/2200rpm and max. torque of 1250Nm/1200~1800rpm, Max.reference torque: 1600 N.m compliant with China V emission standard. Fuel tank capacity: 300 L. AdBlue tank volume: 35L. SC9DF320Q6, in-line, 6-cylinder, water cooled, electric control diesel engine, made by Shanghai Diesel Engine, with rated power of 235kW/1900rpm and max. torque of 1500Nm/1200~1500rpm, Max.reference torque: 1557 N.m compliant with China VI emission standard. Fuel tank capacity: 300 L/350L. AdBlue tank volume: 35L. MC07H.33-60, in-line, 6-cylinder, water cooled, electric control diesel engine, made by SINOTRUK MAN, with rated power of 240kW/2200rpm and max. torque of 1412Nm/1200~1600rpm, Max.reference torque: 1600 N.m compliant with China VI emission standard. Fuel tank capacity: 300 L/350L. AdBlue tank volume: 35L.
Transmission	FAST mechanical control, 9 speed transmission with synchronizers Datong Gear, mechanical control, 9 speed transmission with synchronizers
Axles	High strength axles made by Meritor/Hande, 2nd axle and 3rd axle for driving.
Suspension	Front suspension: longitudinal leaf spring balanced suspension, with cylindrical shock absorber. Rear suspension: lightweight and maintenance-free rubber suspension.
Tires	10 tires and 1 spare tire. Single tire installed on the front axle, double-tire installed on the middle and rear axles. Tire specifications: 315/80R22.5-18PR

 Chassis	
Braking system	Service brake: double-circuit air pressure brake, acting on all wheels; Parking brake: spring-loaded brake, acting on the wheels of axles 2~3. Auxiliary brake: engine exhaust brake, engine retarder brake
Steering system	Mechanically steering mechanism with a hydraulic booster.
Driver's cab	Full-dimension cab, three passengers are allowable. It is equipped with radio-cassette player, adjustable seats, simple sleeper, steering wheel, safety glass, 3 wipers, electrical adjustable mirrors, electrically operated door window lifters, glove box and air conditioning.
Electrical system	24 V DC, two sets of 12 V battery in series. Generator: 28 V-70 A

技术规格

Technical specifications

	Superstructure
Frame	Designed and manufactured by XCMG, made of high strength steel.
Hydraulic system	Variable pump driven by chassis engine, used for hoisting, elevating and telescoping operations. Load sensing proportional multi-way change valve with impact resistance valve and cavitation-proof valve integrated; air-cooled hydraulic oil radiator.
Control system	Pilot hydraulic control is used for controlling the superstructure. All crane movements are controlled by the hydraulic pump and proportional valve through two control levers on the left and right sides.
Main winch system	Hydraulic control is used for speed regulation. The system is driven by a hydraulic motor through a planetary gear reducer, with a normally closed brake, a balance valve and a grooved drum equipped.
Auxiliary winch	Hydraulic control is used for speed regulation. The system is driven by a hydraulic motor through a planetary gear reducer, with a normally closed brake, a balance valve and a grooved drum equipped.
Slewing system	Four-point contact-ball slewing ring is driven by the planetary gear reducer of slewing mechanism, which is driven by a hydraulic motor, and may continuously slew 360°. Power control and free slewing function as well as stepless speed regulation are available. There is a horn switch fitted on the slewing control lever.
Luffing system	A front support double-acting hydraulic cylinder is equipped for luffing operation, with a balance valve fitted.
Operator's cab	New steel cab with a full-view windshield, safety glass, sun shield and adjustable operator's seat. Windshield wiper and roof window wiper are fitted. Crane control levers are integrated into armrests. A sliding door and a pull-out step are designed for easy and safe access to the cab. Air conditioning and heater are standard.
Safety devices	Hydraulic balance valve, hydraulic relief valve, double-way hydraulic valve, LMI, lowering limiter for preventing wire rope from over-releasing, anti-two block at boom head for preventing wire rope from over-winding and tri colored light bar.

	Boom system
Boom	5-section boom with U cross-section, welding structure. Double-cylinder plus ropes telescoping system Boom length: 11.2m~44m.
Single top	Fitted at boom head, used for single line operation. Its lifting performance is the same as that for jib (9 m) with 0° jib offset angle, but the maximum lifting load is no more than 3 t.
Fixed jib	One section lattice jib, welded structure. Three offset angles of 0°, 15° and 30°. Fixed jib length: 9 m.

车型与选装件

Version and optional equipment

车型 Version	功能描述 Function description	选择 Selection
标准型 Standard	五节主臂44m, 固定副臂9m 5-section boom of 44 m, fixed jib of 9 m	

注释：该产品仅标准型一种车型。

Note: only standard version is available for this model.

可选装件 Optional equipment		选择 Selection
回转报警装置 Warning device for slewing		

重量 Weight





车桥 Axle	1	2	3	总重量 Total weight
t	8	13	13	34







吊钩 Hook block	倍率 Parts of line	吊钩重量 Weight (kg)	吊钩尺寸 Dimensions (mm)	备注 Remarks
25t	8	260	366×430×1252	单钩 Single hook
3t	1	60	236×236×503	单钩 Single hook

作业速度 Working speeds



		
315/80 R 22.5	2.5 ~ 90	45%



作业机构 Operation mechanisms	作业速度 Working speed	最大单绳拉力 Max. single line pull	钢丝绳直径/长度 Rope diameter/ length
	0-135 m/min, 单绳, 第四层 m/min, single line, 4th layer	30 kN	16 mm/185m
	0-135 m/min, 单绳, 第四层 m/min, single line, 4th layer	30 kN	16 mm/110 m
	0-2.0 r/min		
	从-2°抬起至79°约35s Approx. 35s for boom luffing from -2° to 79°		
	从11.2m伸出至44m约100s Approx. 100s for boom extending from 11.2m to 44m		

臂架组合方案

Boom / Jib combinations

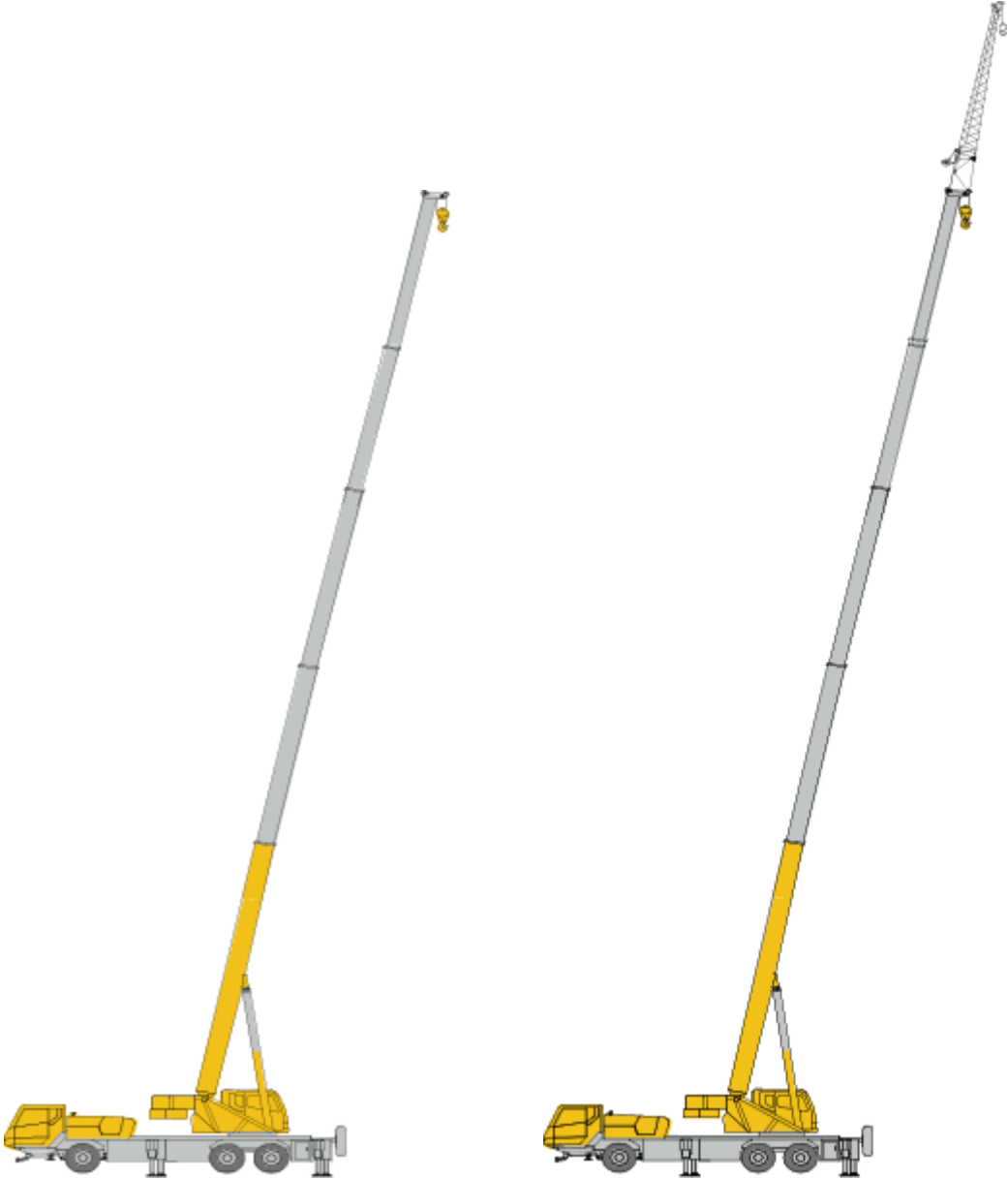

主臂
Telescopic boom

T: 11.2~44m

副臂
Jib

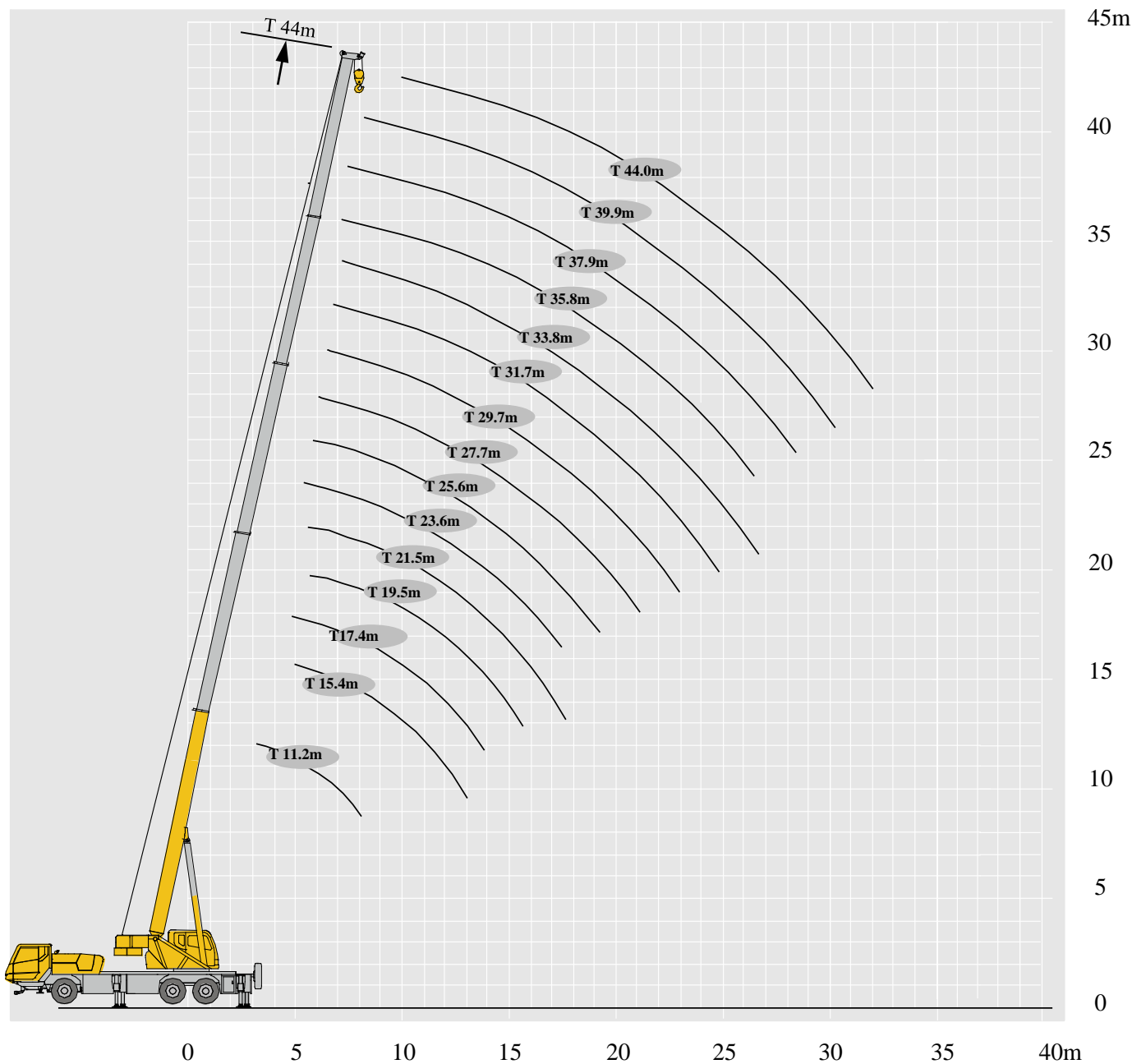

T: 11.2~44m
J: 9 m



起重性能表

Lifting capacities

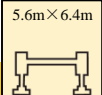

T 11.2~44.0m

	 11.2m	 15.4m	 19.5m	25.6m	31.7m	37.9m	44m	
3	25000	25000						3
3.5	25000	25000						3.5
4	25000	25000	21000					4
4.5	25000	24500	20500					4.5
5	24600	24000	20000	18700				5
5.5	23000	21500	19800	18700				5.5
6	20800	20000	19500	17800				6
6.5	19600	19500	18200	16800	13800			6.5
7	17800	18000	16500	16000	13800			7
8	14400	14000	13800	14500	13000	9800		8
9		11200	11000	11800	12300	9800		9
10		9200	9000	9800	10300	9300	6600	10
11		7700	7500	8200	8700	9000	6400	11
12			6200	7000	7400	7700	6200	12
13			5300	6000	6400	6700	6100	13
14			4400	5100	5600	5800	5900	14
15			3800	4500	4900	5100	5300	15
16				3850	4300	4500	4700	16
18				2900	3300	3600	3800	18
20				2100	2500	2800	3000	20
22					1900	2200	2400	22
24					1400	1700	1900	24
26					1000	1300	1500	26
28						950	1150	28
30						650	850	30
32							600	32

起重性能表

Lifting capacities

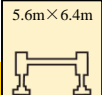
T 17.4~39.9m



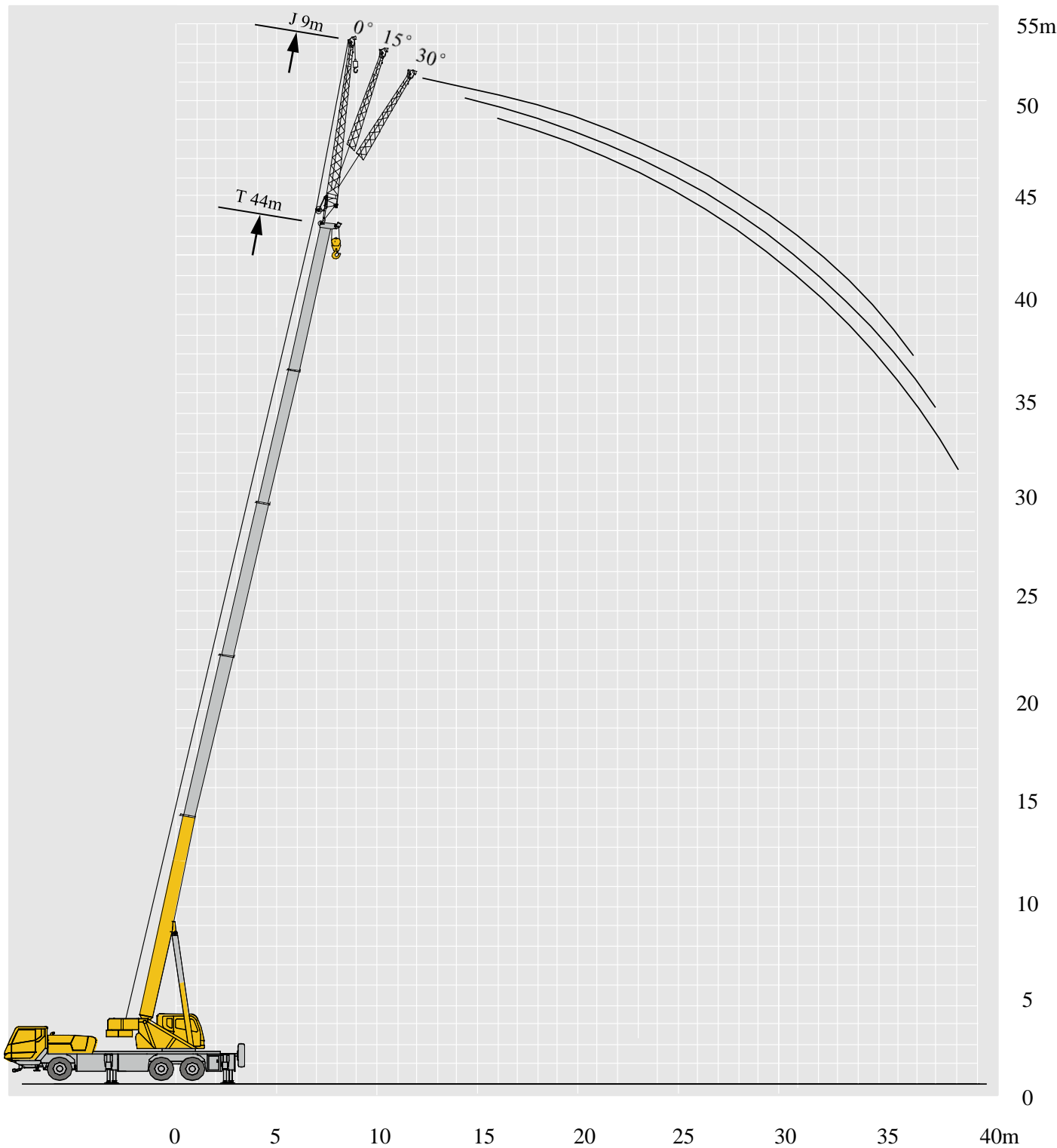

	 17.4m	 23.6m	 29.7m	 35.8m	21.5m	27.7m	33.8m	39.9m	
3	24000								3
3.5	24000								3.5
4	24000				21000				4
4.5	23000	21000			21000				4.5
5	22000	21000			21000				5
5.5	20000	21000			21000	17500			5.5
6	19600	21000	11800		21000	17500			6
6.5	18800	21000	11800		21000	17500			6.5
7	17600	20000	11800		19100	17500	10800		7
8	15500	16000	11300	8500	15000	15500	10800		8
9	12600	13100	10600	8200	12100	12600	10800		9
10	10500	11000	9700	7900	10100	10600	10100	7400	10
11	8900	9300	9000	7300	8500	9000	9200	7100	11
12	7700	8100	8300	6900	7300	7700	8000	6800	12
13		7100	7300	6700	6200	6700	7000	6600	13
14		6200	6400	6400	5400	5800	6100	6100	14
15		5500	5700	5800	4700	5100	5400	5500	15
16		4900	5100	5300	4100	4500	4800	4900	16
18		3900	4100	4300		3600	3800	3900	18
20			3400	3500		2800	3000	3200	20
22			2700	2900		2200	2400	2600	22
24			2200	2400			1900	2100	24
26				2000			1500	1700	26
28				1600				1350	28
30								1050	30
32								800	32

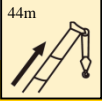
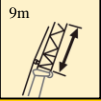
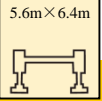

起重性能表

Lifting capacities

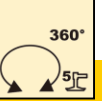
T 44.0m

	    			
	0°	15°	30°	
78	3000	2800	2100	78
75	3000	2500	1900	75
72	2900	2300	1800	72
70	2700	2250	1700	70
65	2200	2000	1600	65
60	1400	1300	1200	60
55	900	800	800	55
50	500	500	500	50

注意事项

Notes

1. 表中额定总起重量值，是在平整的坚固地面上本起重机能够保证的最大总起重量，包括吊钩和吊具的重量，所以为了估算重物重量，必须减去上述的装置重量。
2. 表中的工作幅度为起吊重物离地时起重物到起重机回转轴线的水平距离，是包括起重臂变形量在内的实际值，因而起吊前应考虑起重臂变形量。
3. 只允许在5级(瞬时风速14.1m/s，风压125N/m²)风以下进行作业。
4. 吊重前操作者必须对物体的重量和工作范围了解后选择合适的作业工况，严禁超出表中的数值。幅度及臂长在相邻两个数值之间时，应依据两个数值中较小值确定起重作业。
5. 应按主臂仰角范围作业，即使是空载，也不应使主臂仰角处于范围外，谨防整机倾翻。
6. 表中的主臂长度应要按照每节臂的伸缩要求进行伸出。

1. The total rated loads given in the rated load charts are the maximum lifting capacity when the crane is set up on firm and level ground, which includes the weight of the hook block and slings. The weight of above-mentioned devices should be deducted to correctly calculate the load weight.
2. The working radius shown in the rated load charts is the radius when the load is lifted off the ground, and it is the actual value including loaded boom deflection.
3. A lifting operation is permissible only when the wind force is below grade 5 (instantaneous wind speed is 14.1 m/s, wind pressure is 125 N/m²).
4. Before beginning lifting operation, the operator should know the weight of the load to be lifted and its working range, and then select proper working conditions. Never operate the crane beyond the limit shown in the chart. Use the lower value from the chart when the boom length or working radius is between the range of values.
5. Observe the boom angle limit. Never operate the crane with the boom angle beyond the recommended limit even if a load is not being carried. Otherwise, the crane will tip.
6. The boom length given in the rated load charts should accord with the telescoping code of boom sections .

符号标识

Description of symbols

常规标识

General symbols

	上车 Superstructure		底盘 Chassis
	起重能力 Lifting capacity		车桥 Axle
	吊臂长度 Boom length		行驶速度 Driving speed
	工作幅度 Radius		爬坡能力 Grade ability
	吊臂仰角 Boom angle		轮胎 Tires
	主臂起升高度 Hoist height with boom		支腿 Outriggers
	固定副臂长度 Fixed jib length		吊钩 Hook block
	副臂安装角 Jib offset angle		卷扬 Winch
	副臂起升高度 Hoist height with jib		使用第五支腿360°全回转 360° operation of the boom with 5th jack
			不使用第五支腿侧后方作业 Without 5th jack, boom over side and over rear

主要技术参数表

Table of main technical parameters

类别 Category	项目 Item	单位 Unit	参数 Parameter			
尺寸参数 Dimensions	外形尺寸 (长×宽×高) Dimensions (length×width×height)	mm	13485×2550×3470			
	轴距 Wheel base	mm	4720+1350			
	轮距 (前/后) Track (Front/ Rear)	mm	(2059 (汉德Hande) , 2074 (美驰Meritor)) /1834			
	前悬/后悬 Front/ Rear overhang	mm	(齐星Qixing2488, 南汽NAC2475) /2430			
	前伸/后伸 Front/ Rear extension	mm	(齐星Qixing1937, 南汽NAC1950) /560			
重量参数 Weight	最大允许总质量 Max. permissible total weight	kg	34000			
	轴荷 Axle load	一轴 1st axle	kg	8000		
		二轴 2nd axle	kg	13000		
		三轴 3rd axle	kg	13000		
动力参数 Power	发动机型号 Engine model	—	SC9DF320Q5	MC07H.32-50	SC9DF320Q6	MC07H.33-60
	额定功率/转速 Rated power/rpm	kW/(r/min)	235/1900	235/2200	235/1900	240/2200
	最大净功率/转速 Max. net power/rpm	kW/(r/min)	233/1900	232/2200	232/1900	237/2200
	最大扭矩/转速 Max. torque/rpm	N.m/(r/min)	1350/ (1100~1400)	1250/ (1200-1600)	1500/ (1200~1500)	1412/ (1200~1600)
行驶参数 Travel	最高车速 Max. travel speed	km/h	≥90			
	最低稳定车速 Min. stable travel speed	km/h	2.5 ~ 3			
	最小转弯直径 Min. turning diameter	m	≤21			
	臂头最小转弯直径 Min. turning diameter at boom tip	m	≤25.5			
	最小离地间隙 Min. ground clearance	mm	245			
	接近角 Approach angle	°	12			
	离去角 Departure angle	°	14			
	制动距离(制动初速度为30km/h) Braking distance (at 30 km/h)	m	≤10			
	最大爬坡能力 Max. grade ability	%	≥45			
	百公里油耗 Fuel consumption per 100 km	L	30			
噪音 Noise	加速行驶机外噪声 Exterior noise level	dB(A)	≤84			
	驾驶员耳旁噪声 Noise level at seated position	dB(A)	≤80			

主要技术参数表

Table of main technical parameters

类别 Category	项目 Item		单位 Unit	参数 Parameter	
主要性能参数 Main performance	最大额定总起重量 Max. total rated lifting capacity		t	25	
	最小额定工作幅度 Min. rated working radius		m	3	
	转台尾部回转半径 Turning radius at turntable tail	平衡重处 Counterweight	mm	3800	
		副卷处 Auxiliary winch	mm	—	
	最大起重力矩 Max. load moment	基本臂 Base boom	kN.m	1249	
		最长主臂 Fully-extended boom	kN.m	809	
		最长主臂+副臂 Fully-extended boom + Jib	kN.m	513	
	支腿跨距 Outrigger span	纵向 Longitudinal	m	5.6	
		横向 Lateral	m	6.4	
	起升高度 Hoist height	基本臂 Base boom	m	11.5	
		最长主臂 Fully-extended boom	m	43.8	
		最长主臂+副臂 Fully-extended boom + Jib	m	52	
	起重臂长度 Boom length	基本臂 Base boom	m	11.2	
		最长主臂 Fully-extended boom	m	44	
		最长主臂+副臂 Fully-extended boom + Jib	m	53	
副臂安装角 Jib offset angle		°	0, 15, 30		
工作速度参数 Working speed	起重臂起臂时间 Boom raising time		s	≤35	
	起重臂全伸时间 Boom fully extended time		s	≤100	
	最大回转速度 Max. slewing speed		r/min	≥2.0	
	支腿收放时间 Outrigger extending and retracting time	水平支腿 Outrigger beam	收 Retracting	s	≤20
			放 Extending	s	≤30
		垂直支腿 Outrigger jack	收 Retracting	s	≤25
			放 Extending	s	≤35
起升速度 (单绳,第四层,空载) Hoisting speed (single line, 4th layer, no load)	主起升机构 Main winch		m/min	≥135	
	副起升机构 Auxiliary winch		m/min	≥135	
噪声 Noise	机外辐射 Exterior noise level		dB (A)	≤108	
	司机位置处 Noise level at seated position		dB (A)	≤85	