

QY30K5C汽车起重机 / Truck Crane

技术规格书

Technical specifications



30t



43m



51.1m



目录 Content

目录 Content	
尺寸参数 Dimensions	4
技术规格 Product Specifications	5-8
重量/作业速度 Weight / Working speeds	9
臂架组合方案 Boom / Jib combinations	10
主臂 Boom	11-13
副臂 Jib	14-15
注意事项 Notes	16
符号标识 Description of symbols	17
主要技术参数表 Table of main technical parameters	18-19

尺寸参数

Dimensions

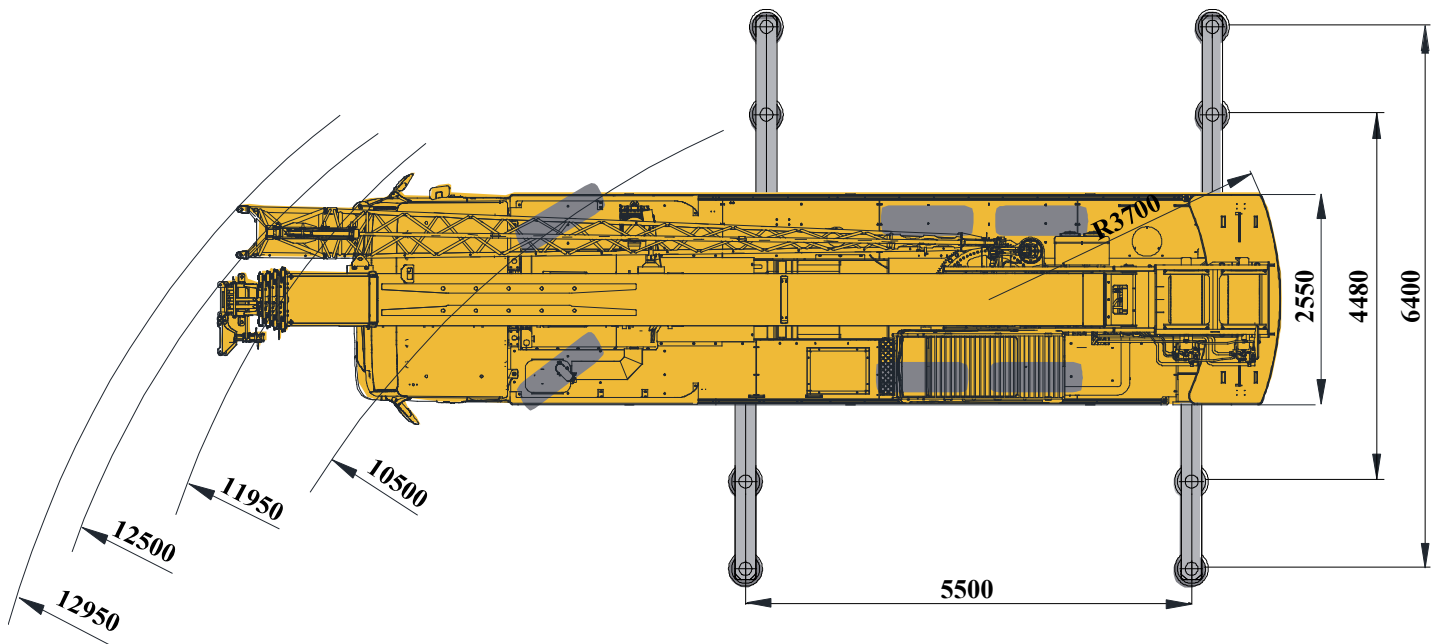
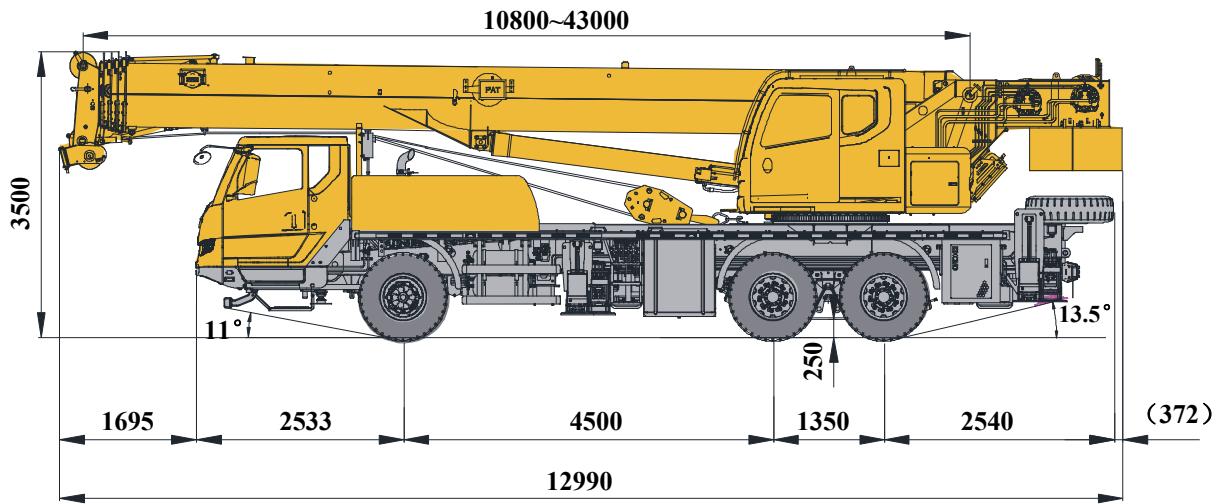

技术规格

Technical specifications

 底盘	配置
车架	徐工设计、制造，全覆盖式走台板，防扭转箱型结构，高强度钢材制造。 ●
支腿	4支腿；纵向H形布置，操作杆控制液压动作；可由底盘任一侧同时或单独控制各支腿的动作，设有水平仪；带第五支腿；且垂直支腿带有液压双向锁。 支脚盘尺寸：φ400mm 最大起重量时支腿反力：323KN ●
发动机	SC9DF300.1Q5，直列六缸水冷电控柴油发动机，上柴，额定功率221kW/2200rpm，最大扭矩1250Nm/1400rpm，国V排放标准。 燃油箱容积：320L。 ●
变速箱	法士特9档变速箱，机械操纵，带同步器。 ●
车桥	配置美驰、汉德高强度车桥，2,3桥驱动。 ●
悬挂	前悬架：纵置钢板弹簧，筒式减震器； 后悬架：橡胶悬架，重量轻，免维护。 ●
轮胎	10个轮胎，1个备胎，前桥装单胎，中桥、后桥装双胎。 轮胎规格：315/80R22.5 ●
制动	行车制动：双回路气压制动，作用于所有车轮。 驻车制动：弹簧贮能制动，作用于2-3轴车轮。 辅助制动：发动机排气制动和缓速制动 ●
转向	机械式转向机构，带有液压助力 ●
驾驶室	全宽驾驶室，乘员3人；配置收放机、可调式座椅、简易卧铺、方向盘、安全玻璃、3只雨刷器、电动后视镜、电动门窗升降器、杂物箱、空调 ●
电气系统	直流24伏特，串联12伏特的电池组2个； 发电机 28伏特-70安培； ●
电气系统	倒车影像 ○

 上车	配置
结构	徐工设计、制造，高强度钢材制造。 ●
液压系统	底盘发动机驱动定量齿轮泵，用于起升、变幅、伸缩。负载敏感式比例多路换向阀，带有抗冲击阀、防气蚀阀；风冷式液压油散热器； 液压油箱容积：600L ●
操纵方式	液控先导操纵系统，由左右2个操纵手柄控制，由液压泵和比例阀进行液控先导式控制起重机的全部动作 ●
主起升机构	液压控制调速，装有双折线绳槽卷筒，由液压马达通过行星齿轮减速器驱动，内置常闭式制动器并带有平衡阀； ●
副起升机构	液压控制调速，装有双折线绳槽卷筒，由液压马达通过行星齿轮减速器驱动，内置常闭式制动器并带有平衡阀； ●
回转机构	四点接触球式回转支承，由液压马达驱动行星齿轮回转机构减速器驱动，可连续回转360°；具有动力控制或自由回转的功能，可无级调速；回转杆设有鸣响开关； ●
变幅机构	单支双作用前置液压变幅油缸，带有平衡阀 ●
操纵室	新型钢制操纵室，装有无视野死角的前景窗，安全玻璃，车窗装有遮阳板，推拉式车门，座椅靠背可倾斜定位，操纵杆安装在座椅两侧的扶手台上；带推拉踏板；前窗顶窗装有雨刮器；标配冷暖空调； ●
安全装置	液压平衡阀；液压溢流阀；液压双向锁；力矩限制器；三圈保护器，防止钢丝绳过放；臂头设置高度限位，防止钢丝绳过卷；三色报警灯； ●
安全装置	风速仪；卷扬监视装置；上车水平仪； ○

技术规格

Technical specifications

 臂架系统	配置
主臂 5节，“U”形截面的筒形焊接结构。 双缸绳排伸缩机构 主臂长度：10.8m~43m。	●
臂端单滑轮 单滑轮, 安装在主臂顶端用于单股钢丝绳 绳起重作业，起重性能与9m副臂 0° 安装角时的起重性能，但最大起重量 不超过3t	●
固定副臂 1节桁架式焊接结构，具有0°、15°、 30°三种固定副臂安装角 固定副臂长度：9m	●

产品各部件明细如上所述，具体部件明细请
参照产品报价单

符号说明：

- —— 表示标准配置；
- —— 表示选装配置。

技术规格

Technical specifications

 Chassis	Configuration
Frame	Designed and manufactured by XCMG, with all covered walking surface, anti-torsion box structure and optimal load-bearing structure design, made of imported high strength steel. ●
Outrigger	4 outriggers, H-shaped arrangement, lateral and vertical outrigger controlled by the hydraulic control. Control levers are located on both sides of the chassis, with a luminous level gauge equipped, with the fifth jack, and the vertical outrigger has two-way hydraulic lock. Outrigger float dimension: φ400mm Max. outrigger reaction force: 323KN ●
Engine	SC9DF300.1Q5, in-line six-cylinder water-cooled EFI diesel engine, manufactured by Shanghai Diesel Engine Co., Ltd., rated power 221kW /2200rpm, max. torque 1250Nm / 1400rpm, the national V emission standards. Fuel tank capacity : 320L ●
Gearbox	FAST manually mechanical control , 9-speed available, synchronizer is equipped. ●
Axles	High strength axle with reliable performance from Meritor. 2nd axle and 3rd axle for driving ●
Suspension	Front suspension: longitudinal leaf spring suspension with barrel shock absorber; Rear suspension: V-type thrust rod structure, and rubber spring suspension. ●
Tires	10 tires and 1 spare tire, front axle is equipped with single tire, middle axle and rear axle are equipped with double tire. Tire specifications:315/80R22.5 ●
Brakes	Service brake: double-circuit air pressure brake, acting on all wheels. Parking brake: spring energy brake, acting on wheels of 2-3 axles. Auxiliary brake: engine exhaust brake and engine in-cylinder brake. ●
Steering	Mechanically steering mechanism with hydraulic power assisted. ●
Driver's cab	Full-dimension driver's cab, three passengers are allowable. Equipped with radio, adjustable seats, simple sleeper , steering wheel, safety glasses, electrically controlled windshield washer, electrically operated rearview mirror , electrically operated door window and glove box. Heater and air conditioner are available. ●
Electrical system	24V DC, two sets of battery. Generator: 28V-70 A ●
Electrical system	Backup camera ○

 Superstructure	Configuration
Frame	Designed and manufactured by XCMG; made of high-strength steel ●
Hydraulic system	Quadruple pump is driven by the engine. constant delivery pump is used for lifting, elevating, telescoping and slewing; Load sensitive proportional multi-way change valve, impact-resistant valve and anti-cavitation corrosion valve are equipped. Air-cooled hydraulic oil radiator; Volume of hydraulic oil tank: 600L ●
Operating mode	Hydraulic pilot control of all crane movements using two control levers. All crane movements are controlled by hydraulic pump and proportional valve. ●
Main winch system	Hydraulic controlled speed regulation, groove drum is equipped, driven by hydraulic motor through planetary gear reducer, and built-in normally closed brake and counterbalance valve are available. ●
Auxiliary winch system	Hydraulic controlled speed regulation, groove drum is equipped, driven by hydraulic motor through planetary gear reducer, and built-in normally closed brake and counterbalance valve are available. ●
Slewing system	Four-point ball contact slewing ring. Slewing system is driven by hydraulic motor, with planetary gear reducer, for 360° continuous rotation, stepless slewing speed regulation is available. Horn button is equipped on the control lever. ●
Elevating System	Single-supported double acting front-mounted hydraulic elevating cylinder, with balance valve equipped. ●
Operator's cab	New fully-enclosed steel tiltable cab with a full-view front window. Safety glass and sun shield are used for windows. Wipers are fitted for the windshield and roof window. The cab features a new ergonomic seat design with backrest adjustment and armrests with joysticks fitted. A sliding door and a pull-out step are available. Heater and air conditioner are available. ●
Safety devices	Hydraulic balance valve; Hydraulic relief valve; Double-way hydraulic valve; LMI; spring aligning device for joystick; Lowering limiter for preventing wire rope from over-releasing; Anti-two block at boom head for preventing wire rope from over-winding; tri-color warning lamp. ●
Safety devices	Anemometer, winch monitor device ; level gauge. ○

技术规格

Technical specifications

 Boom system	Config uration
Boom 5-section, U-shape cross section, welding str-ucture. Boom length: 10.8m ~ 43m.	●
Single top Single top is installed on the top of main boom, for single wire rope hoist. Its lifting performance is the same as that for jib(9m), with 0° jib offset angles.	●
Jib 1-section, Lattice jib, welded structure. Three offset angles of 0° , 15° and 30° . Fixed jib length: 9m	●

Product parts details As mentioned above, please refer to the product quotation for specific parts.

Symbol illustration :

- — standard configuration
- — optional configuration

重量 Weight





车桥 Axle	1	2	3	总重量 Total weight
t	7.5	12.95	12.95	33.4







吊钩 Hook	倍率 No. of lines	吊钩重量 Weight kg	吊钩尺寸 Dimensions mm	备注 Remarks
30t	9	260	366×430×1252	单钩 Single hook , 标配 Standard
3t	1	60	236×236×503	单钩 Single hook , 标配 Standard

作业速度 Working speeds



		
315/80 R 22.5	2.5 ~ 90	40%



作业机构 Drive	作业速度 Working speed	最大单绳拉力 Max. single line pull	钢丝绳直径/长度 Rope diameter/ length
	0-135 m/min, 单绳, 第四层 m/min, single line, 4th layer	32.7 kN	16 mm/185 m
	0-135 m/min, 单绳, 第四层 m/min, single line, 4th layer	29.4 kN	16 mm/110 m
	0-2.5 r/min		
	从-2°抬起至79°约38s Approx. 38s for boom elevation from -2° to 79°		
	从10.8m伸出至43m约100s Approx. 100s for boom extension from 10.8m to 43m		

臂架组合方案

Boom / Jib combinations



主臂
Telescopic boom

T : 10.8~43m

副臂
Jib

T : 10.8~43m
J : 9 m

起升高度曲线图 Lifting heights

主臂
Boom

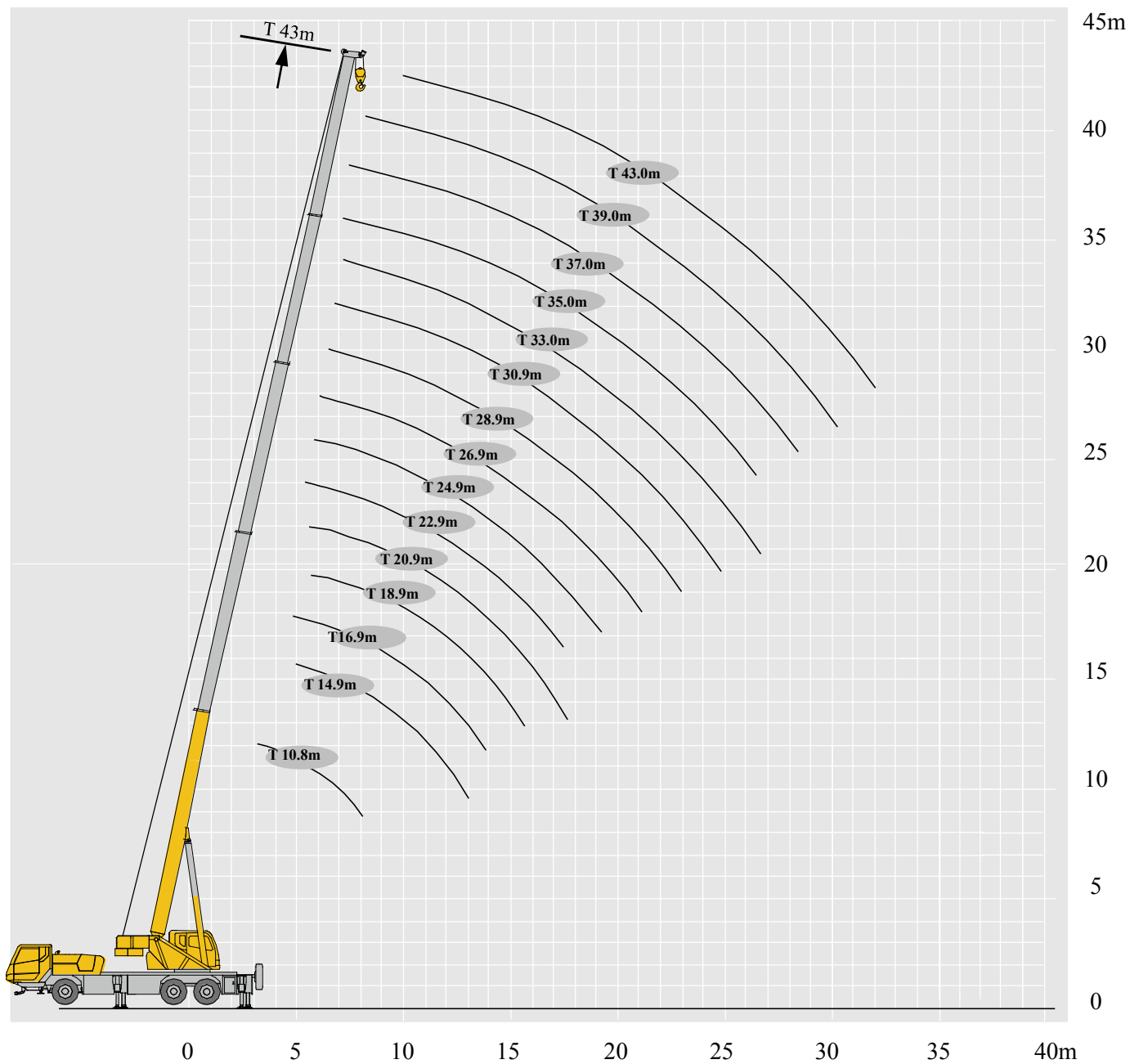

起重性能表

Lifting capacities







T 10.8~43.0m

	 10.8-43.0m	 5.5m×6.4m	 360°					
	10.8m	14.9m	18.9m	24.9m	30.9 m	37.0m	43.0m	
3	30000	25000						3
3.5	25000	24700						3.5
4	25000	23200	17600					4
4.5	24000	22000	17600					4.5
5	23000	21000	17600	16900				5
5.5	21300	20200	17400	16000				5.5
6	19200	19400	16600	15100				6
6.5	17200	17400	15900	14300	12800			6.5
7	15200	15800	15400	13700	12800			7
8	13200	13800	13500	12600	12500	9600		8
9		11100	10800	11600	11500	9500		9
10		9100	8800	9600	10100	9100	6100	10
11		7500	7300	8100	8500	8500	6100	11
12			6100	6900	7300	7600	6100	12
13			5100	5900	6300	6600	5900	13
14			4300	5100	5500	5800	5500	14
15			3600	4400	4800	5100	5200	15
16				3800	4200	4500	4600	16
18				2800	3200	3500	3700	18
20				2100	2500	2800	3000	20
22					1900	2200	2400	22
24					1400	1700	1900	24
26					1000	1300	1500	26
28						900	1100	28
30						700	800	30
32							600	32

起重性能表

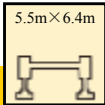
Lifting capacities

T 10.8~43.0m

	   								
	16.9m	22.9 m	28.9m	35.0 m	20.9 m	26.9m	33.0 m	38.9m	
3	20800								3
3.5	20800								3.5
4	20800				20500				4
4.5	20800	19200			20500				4.5
5	20800	18400			19700				5
5.5	19800	17400			18500	16000			5.5
6	19000	16600	11300		17600	16000			6
6.5	18000	15900	11300		16800	15600			6.5
7	16700	15300	11300		16000	14800	10600		7
8	14500	14200	11300	7200	14000	13500	10600		8
9	12500	12800	10400	7200	12000	11800	10600		9
10	10400	10900	9700	7200	9900	10400	10000	6600	10
11	8800	9300	8900	7200	8400	8800	9100	6600	11
12	7600	8000	8300	6900	7200	7600	7900	6600	12
13		7000	7200	6400	6200	6600	6900	6400	13
14		6200	6400	5900	5400	5800	6100	6100	14
15		5500	5700	5500	4700	5100	5400	5500	15
16		4900	5100	5200	4100	4500	4800	4900	16
18		3900	4100	4300		3500	3800	3900	18
20			3400	3500		2800	3000	3200	20
22			2800	2900		2200	2400	2600	22
24			2300	2400			1900	2100	24
26				2000			1500	1700	26
28				1700				1300	28
30								1000	30
32								800	32

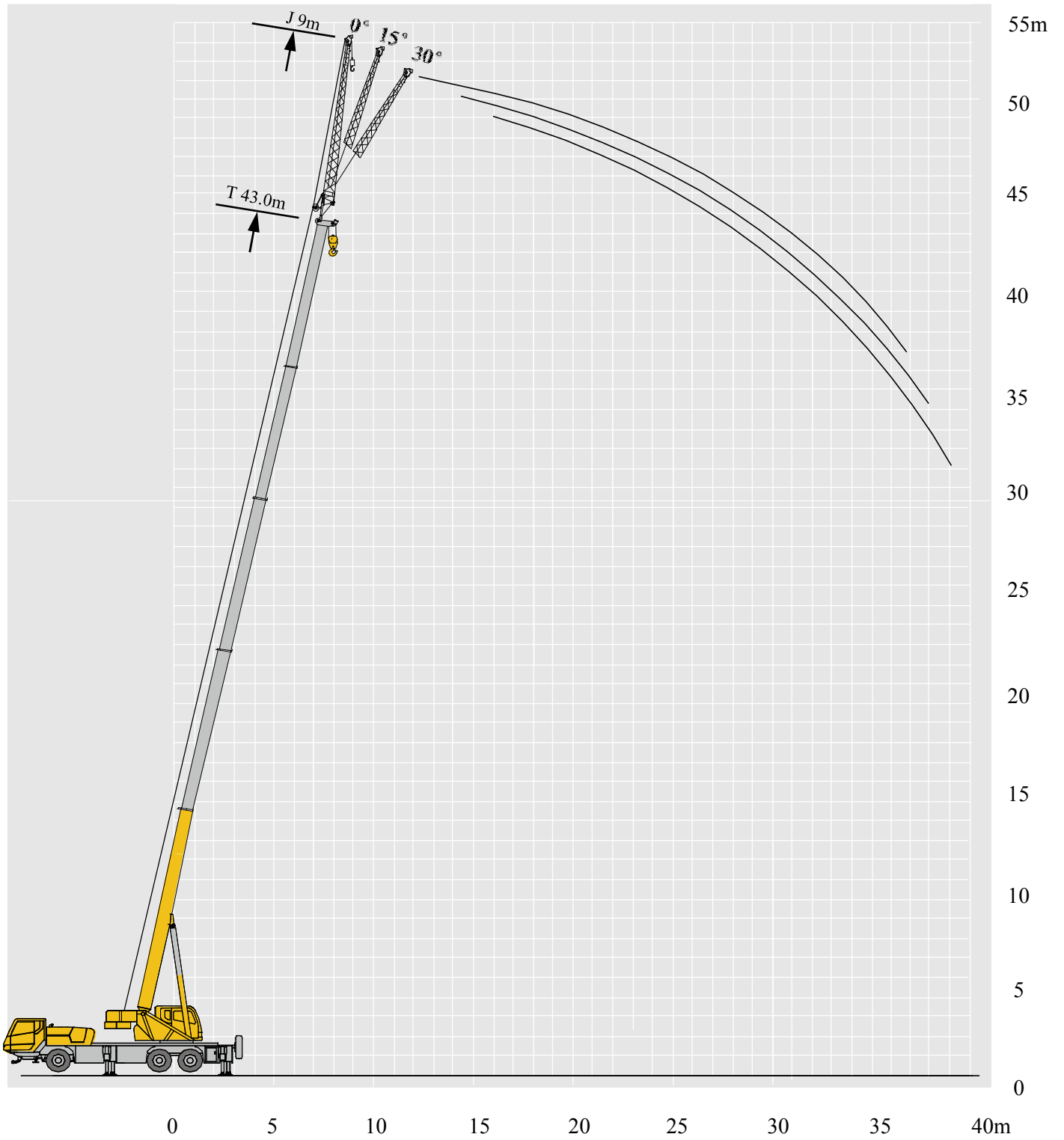

起升高度曲线图
Lifting heights

副臂
Jib

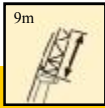
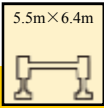

起重性能表
Lifting capacities

T 43.0m

78	    			78
	0°	15°	30°	
78	3000	2800	2100	78
75	3000	2500	1900	75
72	2900	2300	1800	72
70	2700	2250	1700	70
65	2200	2100	1600	65
60	1500	1300	1300	60
55	900	900	800	55
50	600	500	500	50
45	300	300	300	45

注意事项

Notes

1. 表中额定总起重量值，是在平整的坚固地面上本起重机能够保证的最大总起重量，包括吊钩和吊具的重量，所以为了估算重物重量，必须减去上述的装置重量。
2. 表中的工作幅度为起吊重物离地时起重物到起重机回转轴线的水平距离，是包括起重臂变形量在内的实际值，因而起吊前应考虑起重臂变形量。
3. 只允许在5级(瞬时风速14.1m/s，风压125N/m²)风以下进行作业。
4. 吊重前操作者必须对物体的重量和工作范围了解后选择合适的作业工况，严禁超出表中的数值。幅度及臂长在相邻两个数值之间时，应依据两个数值中较小值确定起重作业。
5. 应按主臂仰角范围作业，即使是空载，也不应使主臂仰角处于范围外，谨防整机倾翻。
6. 表中的主臂长度应要按照每节臂的伸缩要求进行伸出。











1. The total rated loads given in the rated load charts are the maximum lifting capacity when the crane is set up on firm and level ground, which includes the weight of the hook block and slings. The weight of above-mentioned devices should be deducted to correctly calculate the load weight.
2. The working radius shown in the rated load charts is the radius when the load is lifted off the ground, and it is the actual value including loaded boom deflection.
3. A lifting operation is permissible only when the wind force is below grade 5 (instantaneous wind speed is 14.1 m/s, wind pressure is 125 N/m²).
4. Before beginning lifting operation, the operator should know the weight of the load to be lifted and its working range, and then select proper working conditions. Never operate the crane beyond the limit shown in the chart. Use the lower value from the chart when the boom length or working radius is between the range of values.
5. Observe the boom angle limit. Never operate the crane with the boom angle beyond the recommended limit even if a load is not being carried. Otherwise, the crane will tip.
6. The boom length given in the rated load charts should accord with the telescoping code of boom sections .

符号标识

Description of symbols

常规标识

General symbols

	上车 Superstructure		底盘 Chassis
	起重能力 lifting capacity		车桥 Axle
	吊臂长度 Boom length		行驶速度 Driving speed
	工作幅度 Radius		爬坡能力 Gradability
	吊臂仰角 Boom position		轮胎 Tyres
	主臂起升高度 Hoist height with Boom		支腿 Outriggers
	固定副臂长度 Fixed jib length		吊钩 Hook block
	副臂安装角 Jib offset angle		卷扬 Winch
	副臂起升高度 Hoist height with jib		使用第五支腿360°全回转 360° rotation with 5th jack
			不使用第五支腿侧后方作业 Over side or over rear of the crane

主要技术参数表

Transportation plan

类别 Category	项目 Item	单位 Unit	参数 Parameter	
尺寸参数 Dimensions	外形尺寸 (长×宽×高) Outline size (length×width×height)	mm	12990×2550×3500	
	轴距 Wheel base	mm	4500+1350	
	轮距 (前/后) Track (Front/ Rear)	mm	2059 (汉德) 2074 (美驰) /1834/1834	
	前悬/后悬 Front/ Rear overhang	mm	2533/2540	
	前伸/后伸 Front/ Rear extension	mm	1695/372	
重量参数 Weight	最大允许总质量 Total weight in travel	kg	33400	
	轴荷 Axle load	一轴 1st axle	kg	7500
		二轴 2nd axle	kg	12950
		三轴 3rd axle	kg	12950
动力参数 Power	发动机型号 Engine model	—	SC9DF300.1Q5	
	额定功率/转速 Engine rated power/rpm	kW/(r/min)	221/2200	
	最大净功率/转速 Max. net power/rpm	kW/(r/min)	—	
	最大输出扭矩/转速 Engine rated torque/rpm	N.m/(r/min)	1250/1400	
行驶参数 Travel	最高车速 Max. travel speed	km/h	≥90	
	最低稳定车速 Min. travel speed	km/h	2.5 ~ 3	
	最小转弯直径 Min. turning diameter	m	≤21	
	臂头最小转弯直径 Min. turning diameter at boom tip	m	≤25.9	
	最小离地间隙 Min. ground clearance	mm	250	
	接近角 Approach angle	°	11	
	离去角 Departure angle	°	13.5	
	制动距离 (制动初速度为30km/h) Braking distance (at 30 km/h)	m	≤10	
	最大爬坡能力 Max. grade ability	%	≥40	
	百公里油耗 Fuel consumption per 100 km	L	30	
噪音 Noise	加速行驶机外噪声 Exterior noise level	dB(A)	≤84	
	驾驶员耳旁噪声 Noise level at seated position	dB(A)	≤90	

主要技术参数表 Transportation plan

类别 Category	项目 Item		单位 Unit	参数 Parameter	
主要性能参数 Main performance	最大额定总起重量 Max. total rated lifting capacity		t	30	
	最小额定工作幅度 Min. rated working radius		m	3	
	转台尾部回转半径 Turning radius at turntable tail	平衡重处 Counterweight	mm	3700	
		副卷处 Auxiliary winch	mm	—	
	最大起重力矩 Max. load moment	基本臂 Base boom	kN.m	1148	
		最长主臂 Fully-extended boom	kN.m	768	
		最长主臂+副臂 Fully-extended boom + Jib	kN.m	503	
	支腿跨距 Outrigger span	纵向 Longitudinal	m	5.5	
		横向 Lateral	m	6.4	
	起升高度 Hoist height	基本臂 Base boom	m	11.2	
		最长主臂 Fully-extended boom	m	42.8	
		最长主臂+副臂 Fully-extended boom + Jib	m	51.1	
起重臂长度 Boom length	基本臂 Base boom	m	10.8		
	最长主臂 Fully-extended boom	m	43.0		
	最长主臂+副臂 Fully-extended boom + Jib	m	52.0		
	副臂安装角 Jib offset angle		°	0、15、30	
工作速度参数 Working speed	起重臂起臂时间 Boom raising time		s	≤38	
	起重臂全伸时间 Boom fully extended time		s	≤100	
	最大回转速度 Max. slewing speed		r/min	≥2.5	
	支腿收放时间 Outrigger extending and retracting time	水平支腿 Outrigger beam	收 Retracting	s	≤20
			放 Extending	s	≤30
		垂直支腿 Outrigger jack	收 Retracting	s	≤25
			放 Extending	s	≤35
起升速度(单绳,第四层,空载) Hoisting speed (single line, 4th layer, no load)	主起升机构 Main winch	m/min	≥135		
	副起升机构 Auxiliary winch	m/min	≥135		
噪声 Noise	机外辐射 Exterior noise level		dB (A)	≤108	
	司机位置处 Noise level at seated position		dB (A)	≤85	