

# XCT100\_1 汽车起重机 / Truck Crane

## 技术规格书

Technical specifications

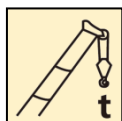

100 t

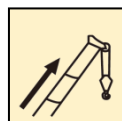

65 m

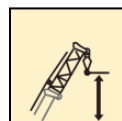

98 m



2020年7月 第4版

# 目录

## Contents

<b>目录</b> <b>Contents</b>	
尺寸参数 Dimensions	3
技术规格 Product specifications	4-8
重量/作业速度 Weight / Working speeds	9
平衡重 Counterweight	10
运输部件尺寸 Dimension and weight of parts transported	11
臂架组合方案 Boom / Jib combinations	12-13
主臂 Boom	14-17
副臂 Jib	18-21
符号标识 Description of symbols	22
主要技术参数表 Table of main technical parameters	23-24
注意事项 Notes	25

# 尺寸参数 Dimensions

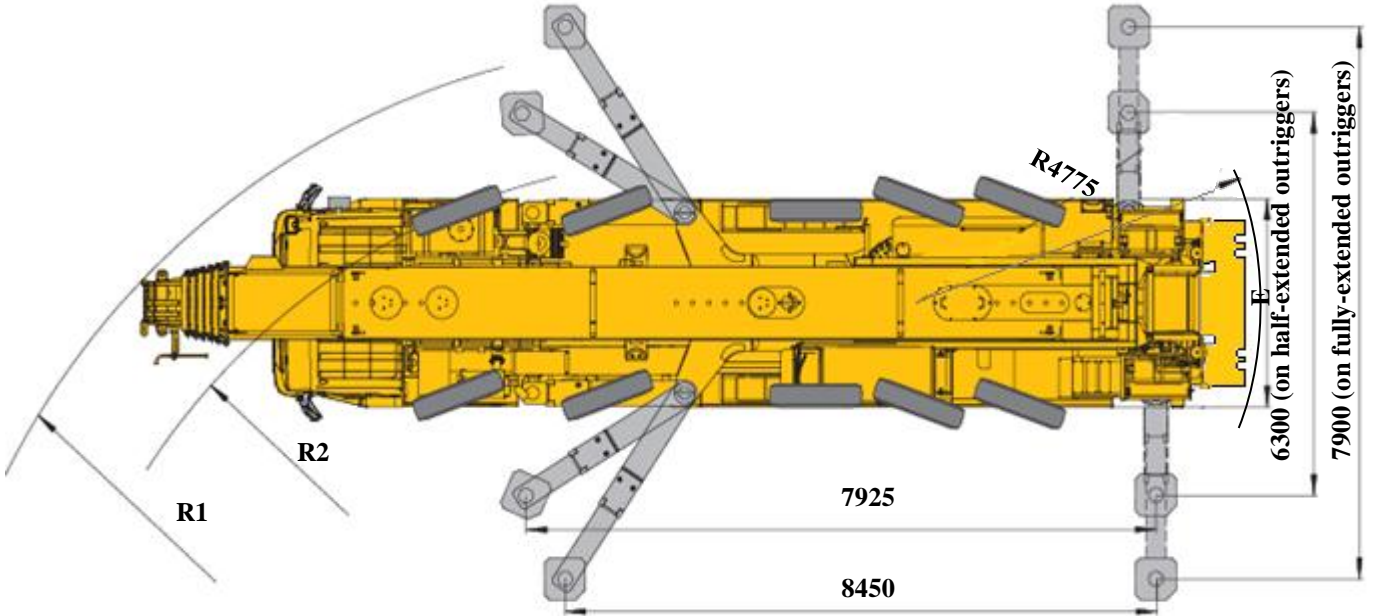
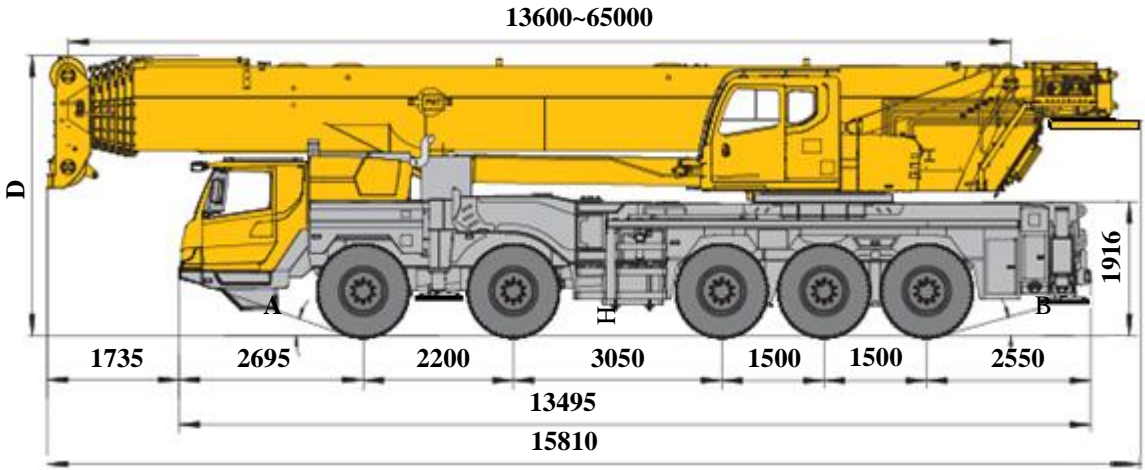

	A	B	D	E	R1	R2	H
385/95 R 25 ( 14.00 R 25 )	20°	14°	3995	3000	11500	10000	380

# 技术规格

## Technical specifications

	底盘	配置
车架	徐工设计、制造，全覆盖式走台板，防扭转箱型结构，高强度钢材制造。	●
支腿	4支腿，前双节摆腿后水平支腿结构，水平伸缩和垂直伸缩由液压控制，底盘两侧装有电控操纵控制台，控制台板装有水平仪、照明灯和调速按钮，支腿油缸均设有单向阀，且垂直支腿带有双向液压锁。 支脚盘尺寸：480mm×615mm 最大起重量时支腿反力：960kN	●
发动机	MC13.48-50，直列六缸水冷电控柴油发动机，重汽曼制造，额定功率356kW/1900rpm，最大扭矩2300Nm/1050-1400rpm，国五排放标准。燃油箱容积：520L。  WP12.460E62，六缸直列，四冲程、增压中冷、水冷、柴油发动机，潍柴制造，额定功率338kW/1900rpm，最大扭矩2200Nm/1000-1400rpm，国六排放标准。燃油箱容积：520L。	●
变速箱	重汽自动变速箱，12个前进档，1个倒档。（国五）  双特自动变速箱，6个前进档，1个倒档。（国六）	●
车桥	名牌厂家高强度车桥，1，2，4，5桥驱动，1，2，4，5桥转向。	●
悬挂	前悬架采用板簧悬架，后悬架采用双纵臂板簧平衡悬架。	●
轮胎	10个轮胎，1个备胎，每桥均装单胎，双钱制造。 轮胎规格：385/95R25（14.00R25）	●

	底盘	配置
制动	行车制动：双回路气压制动，作用于所有车轮。 驻车制动：放气制动，作用于2,3,4,5轴车轮。 辅助制动：发动机排气制动和缓速制动。	●
转向	四桥转向，1、2桥机械转向+液压助力，4/5桥缸控随动转向，可适应多种工况的要求，实现多种转向模式。	●
驾驶室	新型复合结构全宽驾驶室，全封闭、装备豪华舒适。性能上：优越的密封性和防腐蚀、防震设计；配置大视野的前挡风安全玻璃、后视镜，电控洗涤器，电子门窗升降器，带有除霜风挡的室内空气加热器，冷暖空调，收音机、丝网地垫等。主驾采用空气悬浮座椅副驾采用简易卧铺等。2公斤灭火器 标配冷暖空调。	●
电气系统	直流24伏特，串联12伏特的电池组2个。 发电机，28伏特-80安培。	●

# 技术规格

## Technical specifications

 上车	配置
<b>结构</b>	徐工设计、制造，高强度钢材制造。 ●
<b>液压系统</b>	电比例变量泵用于起升、变幅、伸缩；回转采用闭式泵驱动；比例电磁换向控制阀；风冷式液压油散热器；液压油箱有效容积：818L ●
<b>操纵方式</b>	先导电比例操纵，无级调速，由左右2个操纵手柄控制起重机的主要动作。 ●
<b>主起升机构</b>	液压控制调速，由液压马达通过行星齿轮减速器驱动，内置常闭式制动器并带有平衡阀，装有绳槽卷筒。 ●
<b>副起升机构</b>	液压控制调速，由液压马达通过行星齿轮减速器驱动，内置常闭式制动器并带有平衡阀，装有绳槽卷筒。 ●
<b>回转机构</b>	单排四点接触球外齿式回转支承，由液压马达通过行星齿轮减速器驱动，内置常闭式制动器，可连续回转360°，具有动力控制或自由滑转的功能，可无级调速。 ●
<b>变幅机构</b>	单变幅油缸，带有负载补偿功能的变幅平衡阀，变幅下落采用平衡阀外控式重力+动力下降方式。 ●
<b>操纵室</b>	钢制操纵室，无视野死角的前景窗，安全玻璃，推拉式车门，可调式电加热功能座椅，可翻仰20°，装有前窗遮阳帘、顶窗双层遮阳帘，后窗遮阳帘；雨刮器、顶部防护栏、推拉踏板，配备力矩限制器、人机交互系统控制面板、电控扶手箱、发动机动力加速踏板、发动机起动开关等。标配冷暖空调、2kg灭火器。 ●
<b>安全装置</b>	液压平衡阀；液压溢流阀；液压双向锁；力矩限制器；三圈保护器；起升高度限位器；风速仪；卷扬监视装置 ●
<b>组合配重</b>	总重45t，有1.8t、15.8t、22.5t、30t、45t共5种组合方式。 ●

<b>起重钩</b>	130t钩	○
	75t钩	●
	8t钩	●

 臂架系统	配置
<b>主臂</b>	6节，“U”形截面的筒形焊接结构，单板式臂头、紧凑型臂尾。单缸插销伸缩机构 主臂长度：13.6m~65m。 ●
<b>副臂</b>	由连接架、旋转架和两节桁架结构折叠式副臂组成，具有0°、15°、30°三种安装角，收存于主臂旁。 副臂长度：11m、18.5m ●
<b>臂端单滑轮</b>	单滑轮，安装在主臂顶端，用于单股钢丝绳起重作业，起重性能与主臂相同，但最大起重量不超过8t。 ●
<b>主臂加长节</b>	两节桁架式焊接结构，与主臂臂头固定安装 主臂加长节长度：2×8m ○
<b>独立臂头</b>	桁架式焊接结构，与主臂臂头固定安装。 独立臂头长度：2.9m ○

产品各部件明细如上所述，具体部件明细请参照产品报价单

符号说明：

- —— 表示标准配置；
- —— 表示选装配置。

# 技术规格

## Technical specifications

	Chassis	Configuration
<b>Frame</b>	Designed and manufactured by XCMG, it is made of high strength steel with fully covered walking surface and anti-torsion box-typed structure.	●
<b>Outriggers</b>	Four outriggers; front two-stage outrigger beams are swung, and rear outrigger beams are extended. Outrigger beams and jacks are hydraulically controlled. There is an outrigger control station located at each side of the chassis, and there is a level gauge, an illuminator and speed buttons on each control station. There is a check valve fitted in each outrigger cylinder, and a double-way hydraulic valve fitted in each jack cylinder. Float dimension: 480mm×615mm Reaction force of outrigger at max. lifting load: 960kN	●
<b>Engine</b>	MC13.48-50, in-line, 6-cylinder, water cooled, electric control diesel engine, made by SINOTRUK MAN, with rated power of 356kW/1900rpm and max. torque of 2300Nm/1050-1400rpm, compliant to China V emission standard. Fuel tank capacity: 520L. WP12.460E62, 6-cylinder in-line, 4-stroke, turbocharged intercooler, water cooled, diesel engine, made by WEICHAI, with rated power of 338kW/1900rpm and max. torque of 2200Nm/1000-1400rpm, compliant to China VI emission standard. Fuel tank capacity: 520L.	●
<b>Transmission</b>	SINOTRUK automatic transmission, 12-forward speed and 1-reverse speed. (China V) Xi'an FC automatic transmission, 6-forward speed and 1-reverse speed. (China VI)	●
<b>Axles</b>	High strength axles, made by famous manufacturers. 1st, 2nd, 4th and 5th axles are for driving and steering.	●
<b>Suspensions</b>	Leaf springs are adopted for front suspensions; double trailing arm type suspensions are adopted for rear suspensions.	●

	Chassis	Configuration
<b>Tire</b>	10 tires and 1 spare tire, each axle is equipped with single tire, manufactured by Double Coin. Tire specifications: 385/95R25(14.00R25)	●
<b>Braking system</b>	Service brake: double-circuit air pressure brake, acting on all wheels. Parking brake: air-release brake, acting on wheels of axles 2, 3, 4, 5. Auxiliary brake: engine exhaust brake, engine retarder brake	●
<b>Steering system</b>	Four-axle steering; axles 1 and 2 are mechanically steered + hydraulic power assistance, axles 4 and 5 are steered through cylinder control. It is suitable for various demands of working conditions and several steering modes can be realized.	●
<b>Driver's cab</b>	New full-dimension enclosed cab, luxury and comfort. It is designed to be leakproof, anti-corrosive and shockproof. It is equipped with a windshield offering outstanding visibility, electrical adjustable rear mirrors, electric control washer, electronic lifters of doors and windows, air heater with defrosting function, heater & air conditioner, radio player and new material mat, etc. An air suspension seat is supplied for driver and a simple sleeper for co-driver. A fire extinguisher of 2 kg is available. Heater and air conditioner are equipped as a standard.	●
<b>Electrical system</b>	24 V DC, two sets of 12 V battery in series. Generator: 28 V-80 A	●

# 技术规格

## Technical specifications

	Superstructure	Configuration
<b>Frame</b>	Designed and manufactured by XCMG, made of high strength steel.	●
<b>Hydraulic system</b>	Electric proportional variable pump is used for lifting, elevating and telescoping operations. A closed pump is used to drive slewing operation. The proportional solenoid steering control valve; air-cooled hydraulic oil radiator. Effective volume of hydraulic oil tank: 818L	●
<b>Control system</b>	The electric-proportional pilot operation system is equipped with two levers at left and right sides controlling the main movements of the crane, and stepless slewing speed regulation is available.	●
<b>Main winch</b>	Hydraulic control is used for speed regulation. The system is driven by a hydraulic motor through a planetary gear reducer, with a normally closed brake, a balanced valve and a grooved drum equipped.	●
<b>Auxiliary winch</b>	Hydraulic control is used for speed regulation. The system is driven by a hydraulic motor through a planetary gear reducer, with a normally closed brake, a balanced valve and a grooved drum equipped.	●
<b>Slewing system</b>	A single-row, four-point contact-ball external slewing bearing; the system is driven by a hydraulic motor through a planetary gear reducer with constant-closed brake equipped, and may continuously slew 360°. Power control and free slewing function as well as stepless speed regulation are available.	●
<b>Luffing system</b>	Single elevating cylinder and the elevating counterbalance valve with the load compensation function. Balance valve-controlled boom gravity combined with power for lowering boom is used for boom elevating down.	●

	Superstructure	Configuration
<b>Operator's cab</b>	Steel cab with a full-view windshield, safety glass, sliding door, adjustable seat with electric heating function; it can tilt backward about 20°; double-layer sun shield is adopted for roof window; sun shield is also equipped at the windshield and rear window; wipers, roof guardrails, pull-out step, LMI, human-machine interactive control panel, electric controlled armrest, engine accelerator pedal, engine start switch, etc. are also available. Heater, air conditioner and fire extinguisher of 2 kg are standard.	●
<b>Safety devices</b>	Hydraulic counterbalance valve; hydraulic relief valve; hydraulic double-way valve; LMI; lowering limiter; anti-two block; anemometer; winch monitor	●
<b>Combined counterweight</b>	Total weight is 45t. 5 counterweight combinations of 1.8t, 15.8t, 22.5t, 30t and 45t are available.	●
<b>Hook block</b>	130 t	○
	75 t	●
	8 t	●

# 技术规格

## Technical specifications

	<b>Boom and jib</b>	<b>Conf gurat ion</b>
<b>Boom</b>	6-section boom with U-shaped cross-section, welded structure with single-plate boom head and compact boom tail. Single-cylinder pinning telescoping system, Boom length: 13.6m~65m.	●
<b>Jib</b>	The jib consists of a connecting bracket, a rotating bracket and two lattice sections. Three offset angles of 0° , 15° and 30° are available. It is stowed along the side of the boom. Jib length: 11m,18.5m	●
<b>Single top</b>	Installed at the boom top, used for single line operation. Its lifting performance is the same as that for boom, but the max. lifting load could not exceed 8 t.	●
<b>Boom extension</b>	Two-section lattice welded structure, attached to boom head. Length of boom extension: 2×8m.	○
<b>Independent jib head</b>	Lattice jib, welded structure, attached to boom head Length of independent jib head is 2.9 m	○

**Product parts list is as mentioned above. Please refer to the product quotation for specific parts**

● —Standard

○ —Optional



## 重量 Weight



车桥 Axle	1	2	3	4	5	总重量 Total weight
t	10.395	10.395	11.4	11.4	11.4	54.99 <sup>1)</sup>

1) 上车不带起重吊钩、副臂、臂端单滑轮、43.2t平衡重、副起升机构及副卷钢丝绳；驱动转向形式：10×8×8；轮胎规格：385/95 R 25；



Hook block, jib, single top, 43.2 t counterweight, auxiliary winch and wire rope for auxiliary winch are excluded from superstructure. Driving type: 10×8×8; Tire specification: 385/95 R 25







吊钩 Hook	倍率 Parts of lines	吊钩重量 Weight (kg)	吊钩尺寸 Dimensions (mm)	备注 Remarks
130t	12	1017	1785×730×560	双钩 Double hook , 选配 Optional
75t	7	530	1500×590×324	双钩 Double hook , 标配 Standard
8t	1	256	731×426×426	单钩 Single hook , 标配 Standard

## 作业速度 Working speeds



		
385/95 R 25 ( 14.00 R 25 )	1 ~ 90	45%



作业机构 Drive	作业速度 Working speed	最大单绳拉力 Max. single line pull	钢丝绳直径/长度 Rope diameter/ length
	0-135 m/min , 单绳 , 第四层 m/min, single line, 4th layer	104kN	22 mm/280 m
	0-90 m/min , 单绳 , 第四层 m/min, single line, 4th layer	89kN	22 mm/215 m
	0-1.5 r/min		
	从-1°抬起至81°约60s Approx. 60s for boom elevation from -1° to 81°		
	从13.6m伸出至65m约650s Approx. 650s for boom extension from 13.6m to 65m		

# 平衡重 Counterweight

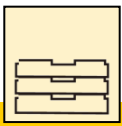
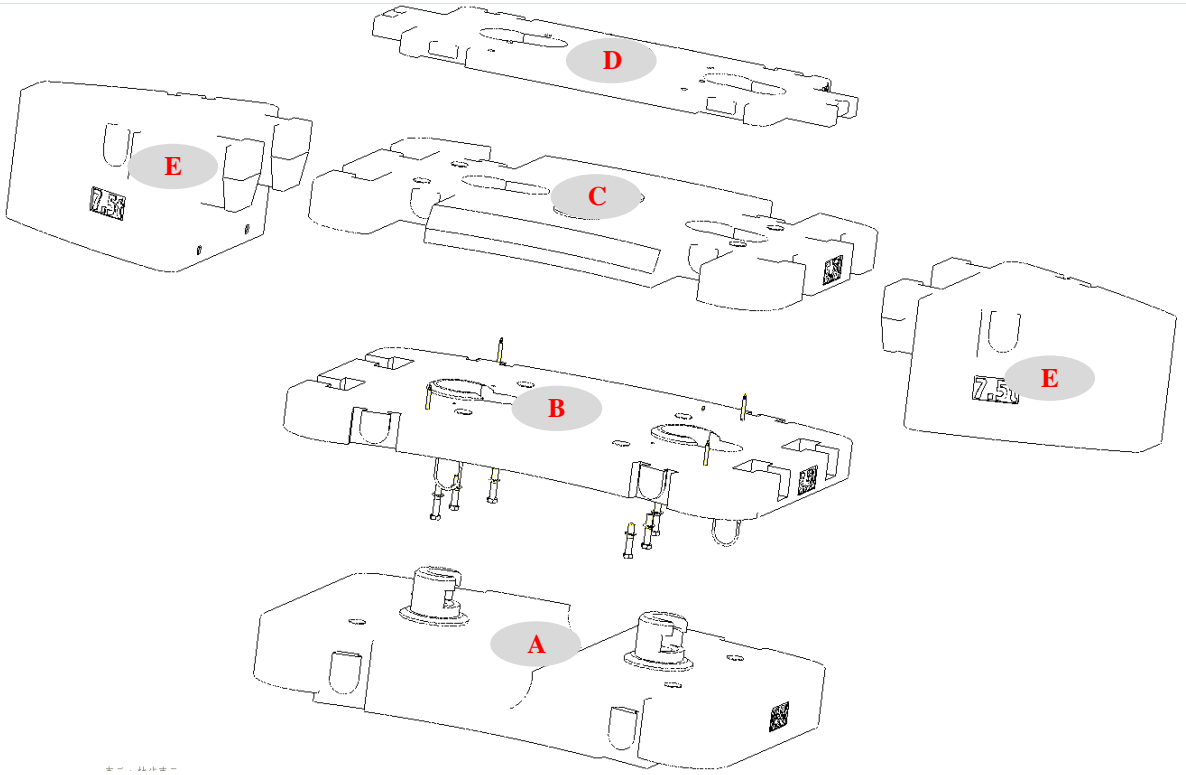

平衡重 Counterweight	A	B	C	D	E
尺寸(长×宽×高) mm Size (L×W×H) mm	2995×2054×697	2995×2054×247	2995×2054×248	2900×1100×110	1592×1575×758
重量 t Weight (t)	14	7.5	6.7	1.8	7.5

工况模式 Working mode	45t	30t	22.5t	15.8t	1.8t
组合形式 Combinations	A+B+C+D+2×E	A+B+C+D	A+C+D	A+D	D

## 运输部件尺寸

### Dimension and weight of parts transported

独立臂头 475kg  
Independent jib head 475kg

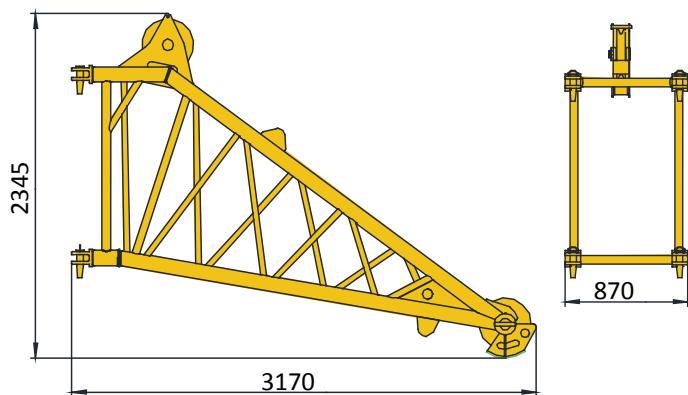

臂端单滑轮83kg  
Single top 83kg

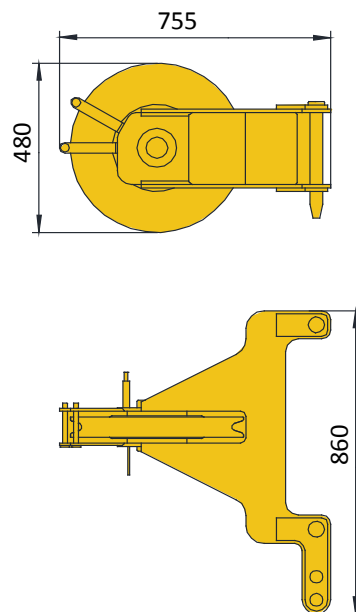



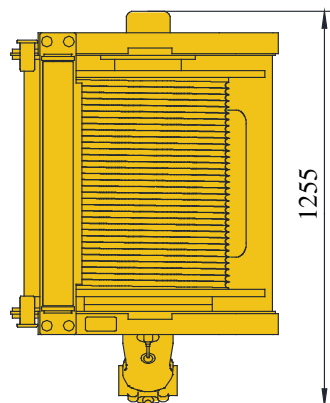
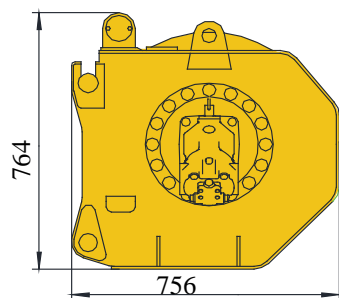

副起升机构(含钢丝绳) 1060kg  
Auxiliary winch (wire rope included) 1060kg

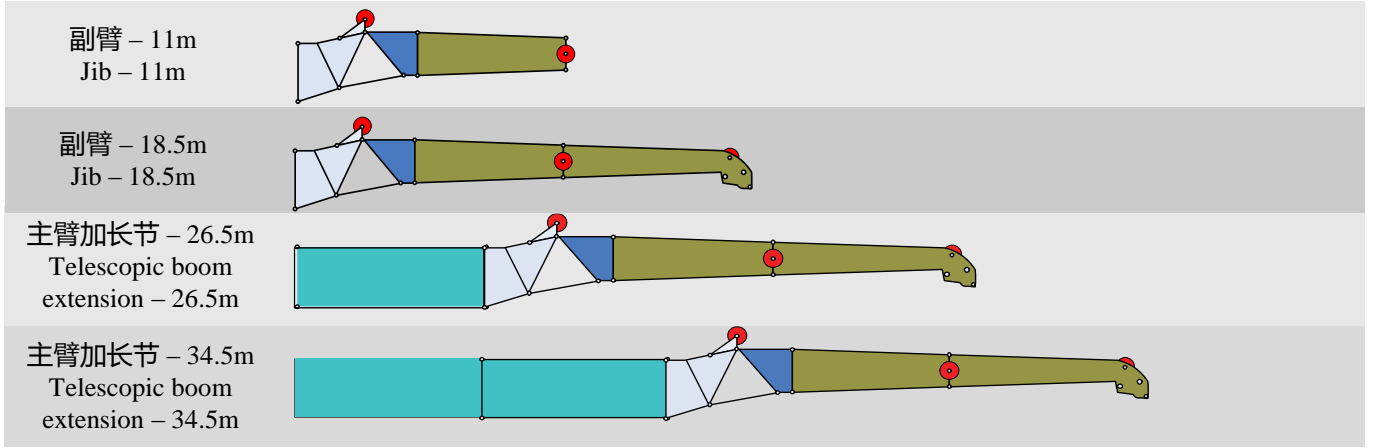

# 臂架组合方案

## Boom / Jib combinations

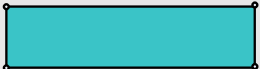

部件 Component	结构形式 Structure	尺寸 (长×宽×高) mm Size (L×W×H) (mm)	重量 kg Weight (kg)
连接架 Connection bracket		2100×800×1820	353
旋转架 Rotating bracket		3050×700×1260	311
主臂加长节 Telescopic boom extension		8000×800×1310	600
一节副臂总成 First jib section assembly		7380×550×750	477
二节副臂总成 Second jib section assembly		7000×410×410	320

# 臂架组合方案

## Boom / Jib combinations

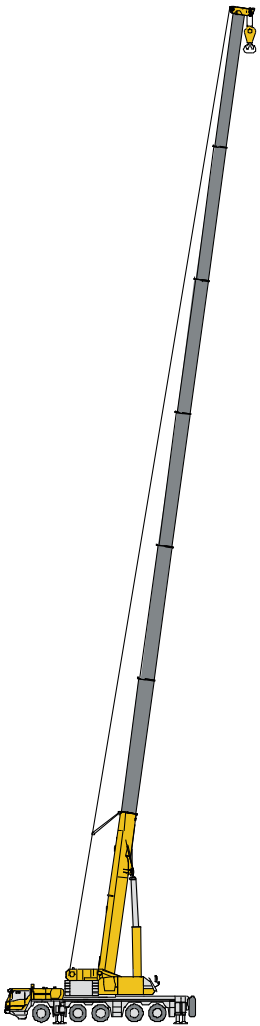

主臂  
Telescopic boom

T : 13.6~65m

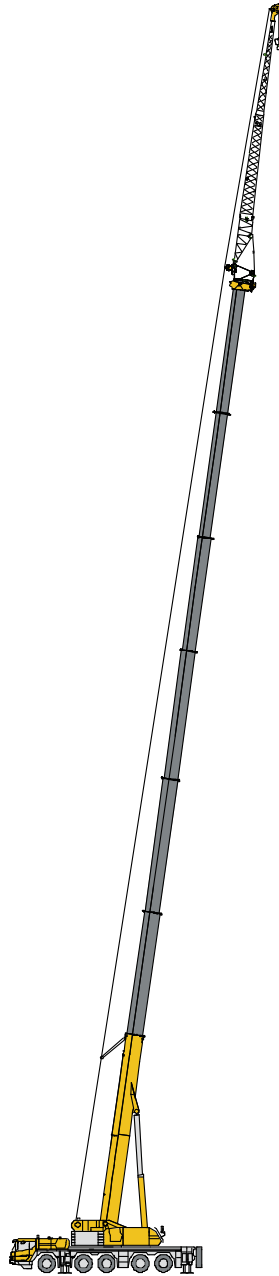

副臂  
Jib

T : 56.2~65m  
J : 11~18.5 m

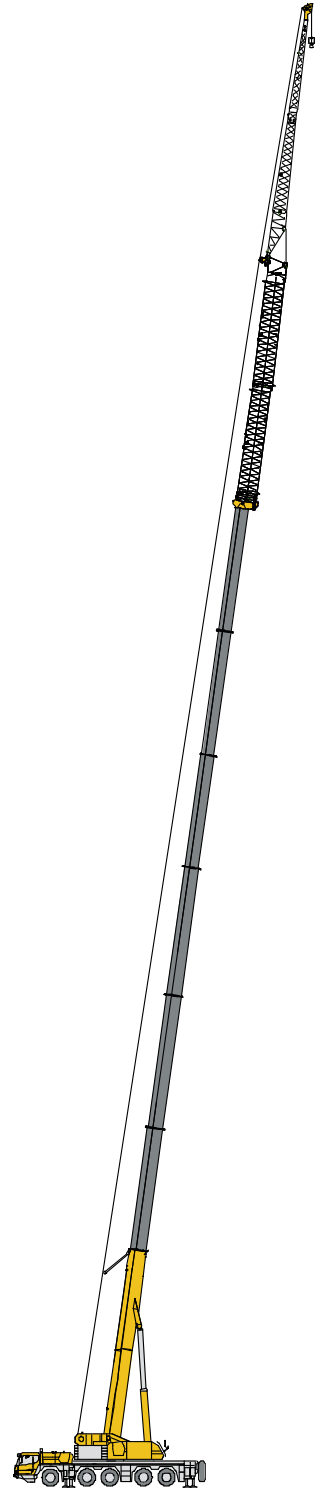

主臂加长节  
Telescopic boom extension

T : 56.2~65m  
I : 8m/16m  
J : 11~18.5m

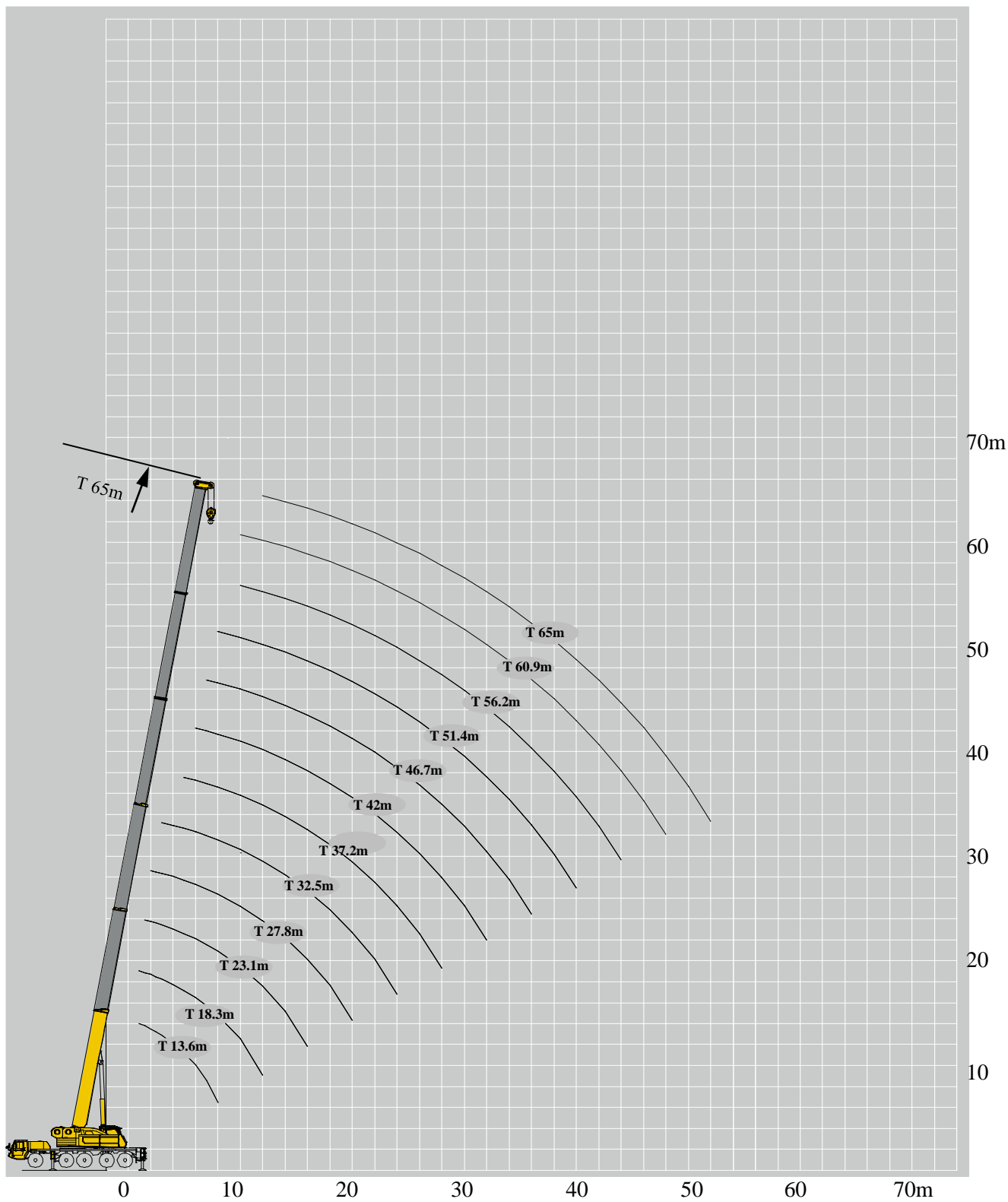

# 起重性能表

## Lifting capacities



T 13.6~65m

	13.6-65m		8.45m×7.9m		360°		45t										
	13.6	18.3	18.3	18.3	23.1	23.1	23.1	27.8	27.8	27.8	32.5	32.5	32.5	37.2	37.2		
3	100.0	100.0	98.0	70.3												3	
3.5	100.0	98.0	95.0	66.9	90.0	88.0	71.8									3.5	
4	100.0	93.0	90.0	63.8	86.0	84.0	68.5	76.0	75.0	72.0						4	
4.5	97.0	90.0	87.0	60.8	81.0	78.0	65.7	76.0	74.0	69.1						4.5	
5	93.0	85.0	82.0	57.9	77.0	75.0	63.3	73.0	71.0	66.5	67.0	67.0	65.0			5	
6	83.0	78.0	76.0	53.2	71.0	69.0	58.7	67.0	65.0	62.4	65.0	65.0	63.0			6	
7	72.0	70.0	70.0	49.2	65.0	63.0	54.6	62.0	60.0	58.2	59.0	60.0	59.0	54.6	56.0	7	
8	61.5	61.5	60.0	45.7	60.0	57.0	50.9	57.0	55.0	55.0	53.3	55.0	55.0	49.8	53.0	8	
9	53.0	54.0	53.0	42.6	54.0	51.0	47.5	52.0	50.0	52.0	48.8	51.0	51.0	45.8	50.0	9	
10	45.0	48.0	45.0	40.0	48.0	46.0	44.0	47.0	45.0	47.0	44.8	47.0	47.0	42.3	46.0	10	
12		39.0	39.0	35.0	39.0	39.0	38.2	38.5	38.0	40.5	38.1	39.0	40.5	34.8	40.0	12	
14		32.0	33.0	31.0	33.0	33.0	33.0	32.0	32.0	34.0	32.1	32.5	34.0	30.6	33.0	14	
16					26.9	28.1	29.0	26.4	27.8	29.2	25.9	27.2	28.8	26.7	28.0	16	
18					22.4	23.4	24.5	21.8	23.2	24.6	21.4	22.6	24.3	22.1	23.6	18	
20								18.3	19.7	21.1	17.9	19.1	20.7	18.6	20.2	20	
22								15.6	16.9	18.3	15.2	16.4	18.0	15.9	17.2	22	
24											13.0	14.1	15.7	13.7	14.9	24	
26											11.2	12.3	13.9	11.9	13.1	26	
														10.3	11.5	28	
														9.0	10.2	30	
组合 Code	00000	00100	00010	00001	01100	00110	00011	11100	01110	00111	21100	11110	01111	21110	11111	组合 Code	

# 起重性能表

## Lifting capacities

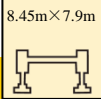
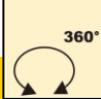
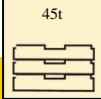
T 13.6~65m

															
	37.2m	42m	42m	42m	46.7m	46.7m	46.7m	51.4m	51.4m	51.4m	56.2m	56.2m	60.9m	65m	
7	38.6														7
8	35.7	36.6	45.9	42.3											8
9	33.4	34.5	42.4	39.4	27.7	24.9	35.0								9
10	31.3	32.6	37.1	35.0	26.2	23.5	33.1	27.8	25.3	23.0					10
12	27.9	29.3	32.5	30.9	23.6	21.1	29.3	25.9	23.0	21.1	21.8	20.0	17.2		12
14	25.0	26.4	28.9	27.8	21.4	19.0	26.2	23.6	21.0	19.3	20.4	18.6	17.2	13.7	14
16	22.7	24.2	25.7	25.1	19.6	17.3	23.6	21.4	19.2	17.7	18.9	17.2	16.6	13.7	16
18	20.8	22.3	22.9	22.6	17.9	15.7	21.2	19.5	17.5	16.2	17.5	15.8	15.5	13.7	18
20	19.1	20.6	19.4	19.8	16.5	14.5	19.2	17.8	16.1	15.0	16.2	14.6	14.5	13.0	20
22	17.7	18.0	16.7	17.0	15.4	13.3	16.6	16.3	14.8	13.9	15.1	13.4	13.5	12.3	22
24	16.1	15.8	14.4	14.8	14.3	12.3	14.3	14.5	13.7	13.0	13.8	12.5	12.6	11.5	24
26	14.3	13.9	12.6	13.0	13.3	11.5	12.5	12.7	12.7	12.1	12.7	11.6	11.5	10.6	26
28	12.8	12.4	11.1	11.4	12.5	10.7	11.0	11.2	11.8	11.2	11.5	10.9	10.6	9.7	28
30	11.5	11.0	9.8	10.1	11.2	10.0	9.7	9.9	10.8	10.5	10.2	10.1	9.8	8.9	30
32		9.8	8.6	9.0	10.1	9.4	8.5	8.7	9.4	9.9	9.0	9.6	9.2	8.2	32
34		8.8	7.7	8.0	9.1	8.7	7.6	7.8	8.4	9.1	8.1	8.9	8.5	7.7	34
36					8.1	8.3	6.7	6.9	7.6	8.3	7.2	8.1	7.6	7.1	36
38					7.4	7.8	6.0	6.1	6.8	7.5	6.4	7.3	6.8	6.6	38
40								5.5	6.2	6.8	5.8	6.6	6.2	6.2	40
42								4.9	5.6	6.1	5.2	6.0	5.6	5.6	42
44											4.6	5.4	5.1	5.1	44
46											4.2	4.9	4.6	4.6	46
48													4.1	4.1	48
50													3.7	3.7	50
52														3.3	52
54														2.9	54
组合 Code	01112	11112	21111	12111	11122	01222	22111	22211	12221	11222	22221	12222	22222	33333	组合 Code



# 起升高度曲线图 Lifting heights

副臂  
Jib

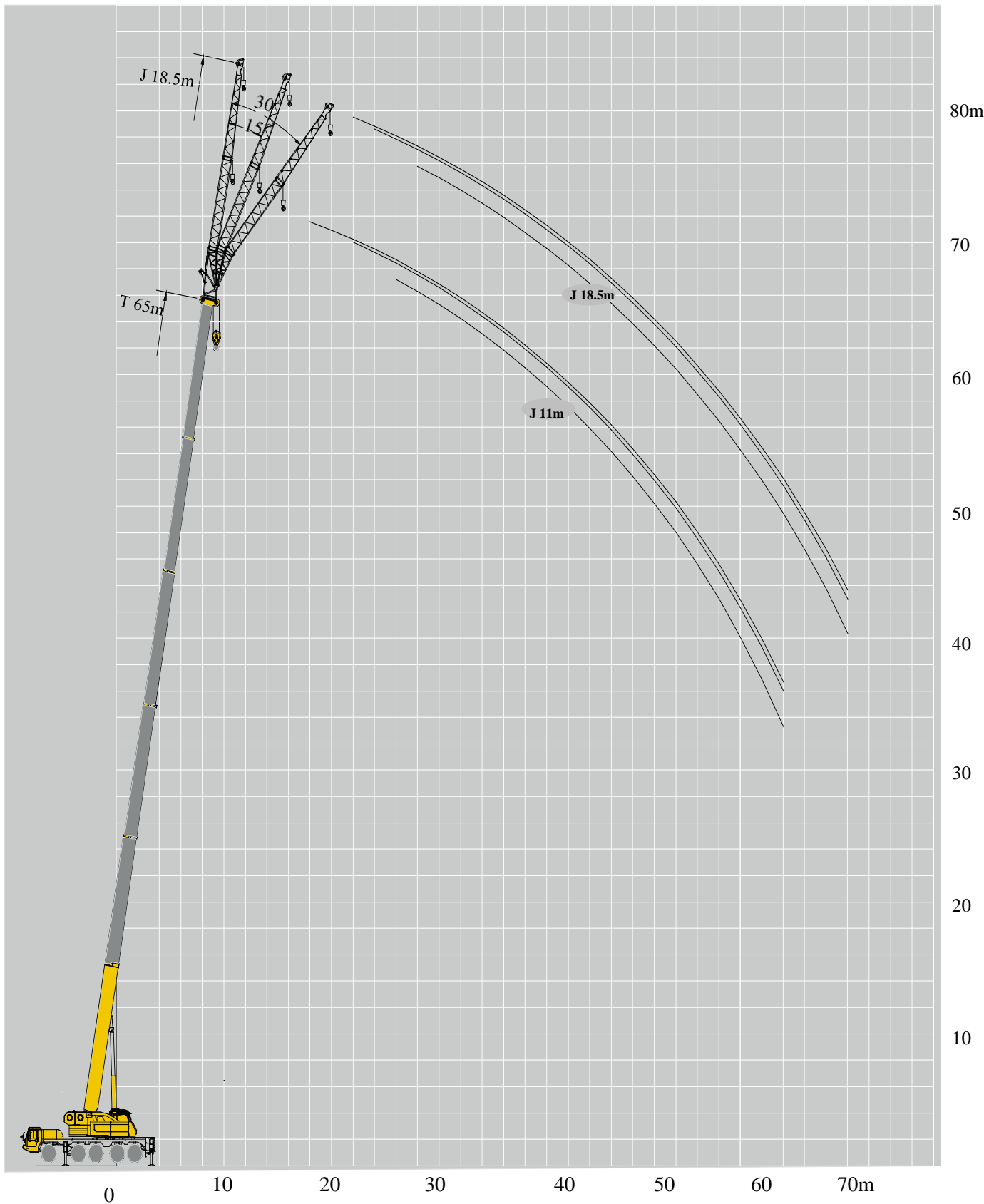

# 起重性能表

## Lifting capacities

J 11m/18.5 m

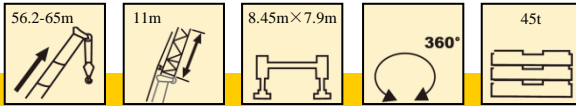

	56.2 m			60.9 m			65 m			
	11m									
	0°	15°	30°	0°	15°	30°	0°	15°	30°	
16	8.0									16
18	8.0	6.0		7.6			7.0			18
20	8.0	5.9	4.4	7.4	5.8		6.9	5.4		20
22	7.8	5.8	4.2	7.2	5.5	4.2	6.8	5.3	4.1	22
24	7.5	5.6	4.0	7.1	5.4	4.0	6.6	5.1	4.0	24
26	7.2	5.4	3.9	6.8	5.3	3.9	6.5	5.1	3.9	26
28	7.0	5.4	3.8	6.6	5.2	3.8	6.4	5.1	3.8	28
30	6.7	5.1	3.6	6.5	5.1	3.6	6.2	4.9	3.6	30
32	6.6	5.0	3.5	6.3	5.0	3.5	6.1	4.8	3.5	32
34	6.4	4.9	3.4	6.3	4.8	3.4	6.1	4.7	3.4	34
36	6.2	4.7	3.3	6.1	4.7	3.4	5.8	4.7	3.3	36
38	6.0	4.4	3.2	5.9	4.5	3.2	5.2	4.6	3.2	38
40	5.9	4.2	3.2	5.6	4.3	3.1	4.9	4.5	3.1	40
42	5.3	4.1	3.0	5.2	4.1	3.1	4.7	4.2	3.0	42
44	4.8	3.9	3.0	4.8	4.0	3.0	4.1	4.1	3.0	44
46	4.3	3.8	3.0	4.5	3.9	2.9	3.9	3.8	2.9	46
48	3.8	3.7	2.9	4.1	3.8	2.9	3.6	3.5	2.9	48
50	3.4	3.6	2.8	3.6	3.6	2.9	3.3	3.3	2.8	50
52	3	3.2	2.8	3.3	3.4	2.8	3.0	3.1	2.8	52
54	2.7	2.8	2.7	2.9	3.1	2.8	2.9	2.8	2.8	54
56				2.6	2.7	2.8	2.6	2.7	2.6	56
58				2.3	2.4	2.5	2.3	2.4	2.4	58
60							2	2.1	2.1	60
62								1.8	1.9	62
组合Code	22221			22222			33333			组合Code

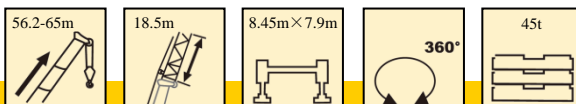

	56.2 m			60.9 m			65 m			
	18.5m									
	0°	15°	30°	0°	15°	30°	0°	15°	30°	
18	4.1									18
20	4.1			3.8						20
22	4.0	2.8		3.8			3.5			22
24	3.9	2.7		3.7	2.7		3.5	2.6		24
26	3.8	2.5	1.8	3.6	2.5		3.5	2.5		26
28	3.7	2.4	1.8	3.6	2.4	1.8	3.4	2.4	1.8	28
30	3.3	2.3	1.8	3.5	2.3	1.8	3.3	2.2	1.8	30
32	3.2	2.2	1.7	3.3	2.2	1.7	3.3	2.1	1.7	32
34	3.0	2.0	1.6	3.1	2.0	1.7	3.2	2.0	1.7	34
36	2.8	2.0	1.6	2.9	2.0	1.6	3.1	1.8	1.6	36
38	2.6	2.0	1.6	2.8	1.8	1.6	2.9	1.8	1.6	38
40	2.5	1.8	1.5	2.7	1.8	1.5	2.7	1.7	1.6	40
42	2.3	1.8	1.5	2.6	1.8	1.5	2.6	1.7	1.5	42
44	2.2	1.6	1.4	2.4	1.8	1.4	2.5	1.6	1.4	44
46	2.1	1.5	1.4	2.3	1.7	1.4	2.4	1.6	1.4	46
48	2.0	1.5	1.2	2.2	1.6	1.2	2.3	1.5	1.2	48
50	2.0	1.5	1.2	2.1	1.6	1.2	2.1	1.4	1.2	50
52	1.8	1.4	1.2	1.9	1.6	1.2	2.1	1.4	1.2	52
54	1.7	1.4	1.2	1.9	1.4	1.2	2.0	1.4	1.2	54
56	1.7	1.3	1.2	1.8	1.3	1.2	1.9	1.4	1.2	56
58	1.6	1.3	1.2	1.8	1.3	1.2	1.9	1.4	1.2	58
60	1.6	1.3	1.2	1.6	1.3	1.2	1.8	1.3	1.2	60
62	1.5	1.3	1.2	1.6	1.3	1.2	1.7	1.3	1.2	62
64				1.6	1.3	1.2	1.6	1.3	1.2	64
66						1.2	1.5	1.2	1.1	66
68							1.3	1.2	1.1	68
组合Code	22221			22222			33333			组合Code

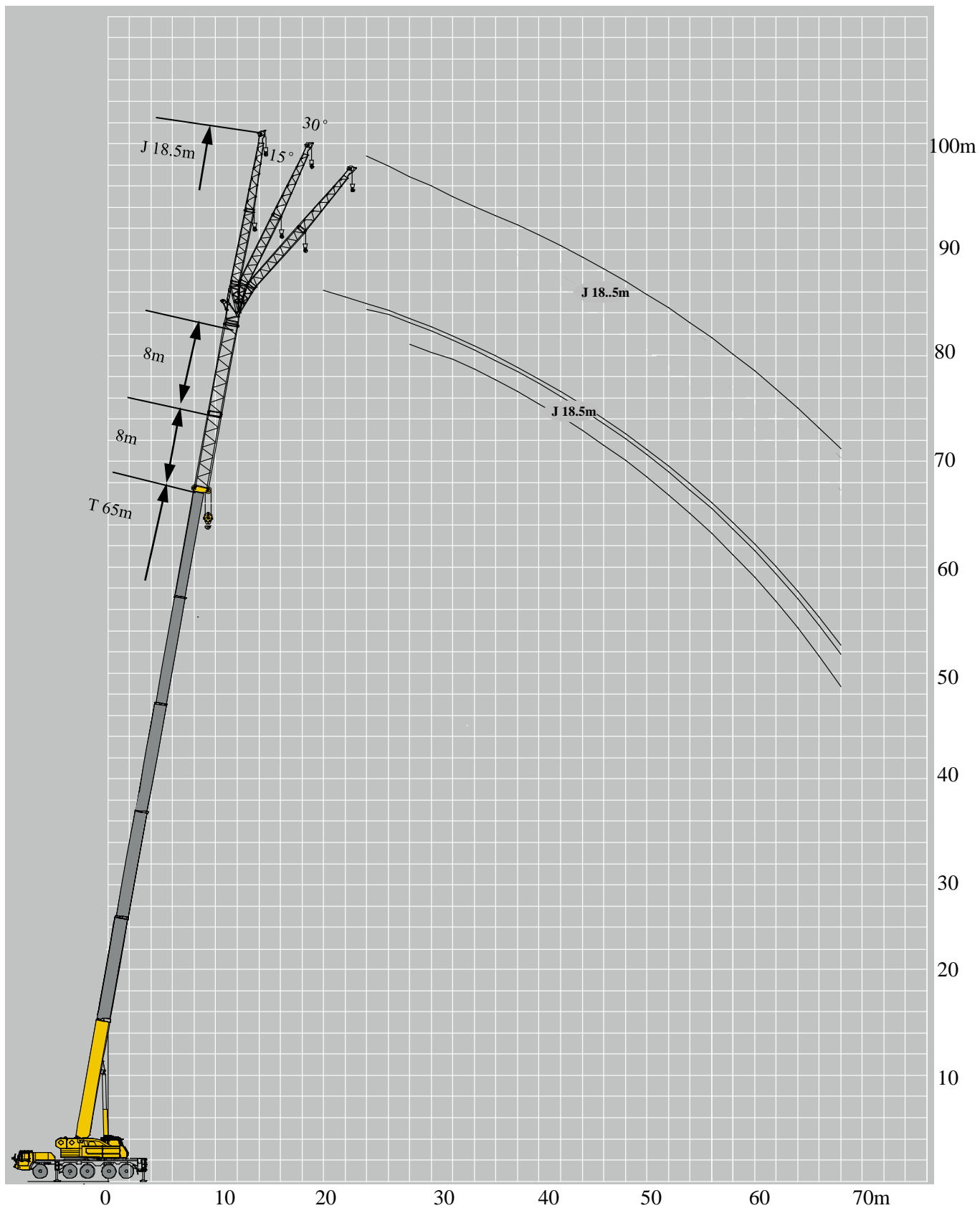

# 起重性能表

## Lifting capacities

I 8m/16m

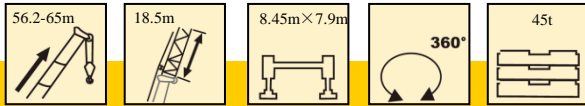

	56.2+8 m			60.9+8 m			65+8 m				
	18.5 m										
	0°	15°	30°	0°	15°	30°	0°	15°	30°		
18	3.6										
20	3.6			3.3						20	
22	3.6	2.6		3.3				3.0		22	
24	3.6	2.6		3.3	2.5			3.0		24	
26	3.6	2.4	1.8	3.3	2.5			3.0	2.4	26	
28	3.6	2.3	1.8	3.3	2.4	1.8		3.0	2.4	28	
30	3.5	2.2	1.8	3.2	2.2	1.8		3.0	2.3	1.7	30
32	3.4	2.1	1.7	3.2	2.1	1.8		3.0	2.2	1.7	32
34	3.3	1.9	1.7	3.1	2.1	1.7		3.0	2.1	1.7	34
36	3.1	1.9	1.7	3.1	2.0	1.7		2.9	2.1	1.7	36
38	2.9	1.8	1.6	3.0	1.9	1.6		2.9	2.0	1.6	38
40	2.7	1.7	1.6	2.9	1.8	1.6		2.9	1.8	1.6	40
42	2.6	1.7	1.5	2.7	1.8	1.5		2.8	1.8	1.5	42
44	2.5	1.6	1.4	2.6	1.7	1.4		2.8	1.7	1.4	44
46	2.3	1.6	1.3	2.5	1.7	1.3		2.6	1.7	1.3	46
48	2.2	1.6	1.3	2.4	1.6	1.3		2.5	1.6	1.3	48
50	2.1	1.5	1.2	2.2	1.5	1.2		2.3	1.6	1.2	50
52	2.1	1.4	1.2	2.2	1.4	1.2		2.3	1.6	1.2	52
54	2.0	1.4	1.1	2.1	1.4	1.1		2.2	1.5	1.1	54
56	1.9	1.4	1.1	2.0	1.4	1.1		2.1	1.4	1.1	56
58	1.8	1.3	1.1	1.9	1.4	1.1		2.0	1.4	1.1	58
60	1.8	1.3	1.1	1.9	1.4	1.1		1.7	1.4	1.1	60
62	1.7	1.3	1.1	1.8	1.3	1.1		1.7	1.4	1.1	62
64	1.6	1.3	1.1	1.7	1.3	1.1		1.4	1.4	1.1	64
66	1.6	1.3	1.1	1.7	1.3	1.1		1.4	1.3	1.1	66
68	1.4	1.2	1.1	1.5	1.3	1.1		1.2	1.2	1.1	68
组合Code	22221			22222			33333			组合Code	

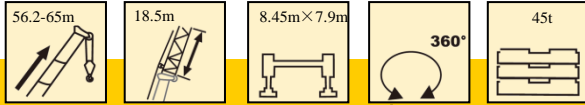

	56.2+16 m			60.9+16 m			65+16 m		
	18.5 m								
	0°	15°	30°	0°	15°	30°	0°		
20	3.2							20	
22	3.2				2.8			22	
24	3.2	2.4			2.8		2.6	24	
26	3.2	2.4			2.8	2.4	2.6	26	
28	3.2	2.4	1.4		2.8	2.4	2.6	28	
30	3.2	2.4	1.4		2.8	2.4	1.4	2.6	30
32	3.2	2.3	1.4		2.8	2.4	1.4	2.6	32
34	3.1	2.2	1.4		2.8	2.2	1.4	2.6	34
36	3.1	2.0	1.4		2.8	2.1	1.4	2.6	36
38	3.0	1.9	1.4		2.7	2.0	1.4	2.6	38
40	2.9	1.9	1.4		2.7	1.9	1.4	2.6	40
42	2.9	1.8	1.3		2.7	1.9	1.4	2.5	42
44	2.7	1.7	1.3		2.6	1.8	1.3	2.5	44
46	2.5	1.7	1.3		2.6	1.7	1.3	2.5	46
48	2.4	1.6	1.3		2.6	1.7	1.3	2.5	48
50	2.3	1.6	1.2		2.5	1.7	1.3	2.3	50
52	2.3	1.6	1.2		2.4	1.6	1.2	2.1	52
54	2.2	1.5	1.2		2.3	1.6	1.2	1.9	54
56	2.1	1.4	1.1		2.2	1.4	1.2	1.7	56
58	2.0	1.4	1.1		1.9	1.4	1.1	1.6	58
60	1.9	1.4	1.1		1.8	1.4	1.1	1.4	60
62	1.9	1.4	1.1		1.6	1.4	1.1	1.2	62
64	1.8	1.3	1.1		1.5	1.3	1.1	1.2	64
66	1.6	1.3	1.1		1.5	1.3	1.1		66
68	1.4	1.2	1.1		1.3	1.3	1.1		68
组合Code	22221			22222			33333	组合code	

# 符号标识

## Description of symbols

### 常规标识

#### General symbols

	上车 Superstructure		底盘 Chassis
	起重能力 Lifting capacity		车桥 Axle
	吊臂长度 Boom length		行驶速度 Driving speed
	工作幅度 Radius		爬坡能力 Grade ability
	吊臂仰角 Boom angle		轮胎 Tires
	主臂起升高度 Hoist height with boom		支腿 Outriggers
	固定副臂长度 Fixed jib length		吊钩 Hook block
	副臂安装角 Jib offset angle		平衡重 Counterweight
	副臂起升高度 Hoist height with jib		卷扬 Winch
	独立臂头 Independent jib head		360°全回转 360° rotation
	主臂加长节 Boom extension		

# 主要技术参数表

## Transportation plan

类别 Category	项目 Item	单位 Unit	参数 Parameter		
尺寸参数 Dimensions	外形尺寸 (长×宽×高) Dimensions (length×width×height)	mm	15810×3000×3990		
	轴距 Wheel base	mm	2200+3050+1500+1500		
	轮距 (前/后) Track (Front/ Rear)	mm	2528/2528/2518/2518/2518		
	前悬/后悬 Front/ Rear overhang	mm	2695/2760		
	前伸/后伸 Front/ Rear extension	mm	1735/365		
重量参数 Weight	最大允许总质量 Max. permissible weight	kg	54990		
	轴荷 Axle load	一轴 1st axle	kg	10395	
		二轴 2nd axle	kg	10395	
		三轴 3rd axle	kg	11400	
		四轴 4th axle	kg	11400	
五轴 5th axle		kg	11400		
动力参数 Power	发动机型号 Engine model	—	MC13.48-50 (国五China V)	WP12.460E62 (国六China VI)	
	额定功率/转速 Rated power/rpm	kW/(r/min)	356/1900	338/1900	
	最大净功率/转速 Max. net power/rpm	kW/(r/min)	353/1900	333/1900	
	最大输出扭矩/转速 Max. output torque/rpm	N.m/(r/min)	2300/1050-1400	2200/1000-1400	
行驶参数 Travel	最高车速 Max. travel speed	km/h	≥90		
	最低稳定车速 Min. travel speed	km/h	3		
	最小转弯直径 Min. turning diameter	m	≤20		
	臂头最小转弯直径 Min. turning diameter at boom tip	m	≤24.7		
	最小离地间隙 Min. ground clearance	mm	380		
	接近角 Approach angle	°	20		
	离去角 Departure angle	°	14		
	制动距离 (制动初速度为30km/h) Braking distance (at 30 km/h)	m	≤10		
	最大爬坡能力 Max. grade ability	%	≥45		
	百公里油耗 Fuel consumption per 100 km	L	65		
噪音 Noise	加速行驶机外噪声 Exterior noise level	dB(A)	≤88		
	驾驶员耳旁噪声 Noise level at seated position	dB(A)	≤90		

# 主要技术参数表

## Table of main technical parameters

类别 Category	项目 Item		单位 Unit	参数 Parameter	
主要性能参数 Main performance	最大额定总起重量 Max. total rated lifting capacity		t	100	
	最小额定工作幅度 Min. rated working radius		m	3	
	转台尾部回转半径 Turning radius at turntable tail	平衡重处 Counterweight	mm	5120	
		副卷处 Auxiliary winch	mm	4965	
	最大起重力矩 Max. load moment	基本臂 Base boom	kN.m	4939	
		最长主臂 Fully-extended boom	kN.m	2713	
		最长主臂+副臂 Fully-extended boom + Jib	kN.m	1176	
	支腿跨距 Outrigger span	纵向 Longitudinal	m	8.45	
		横向 Lateral	m	7.9	
	起升高度 Hoist height	基本臂 Base boom	m	14	
		最长主臂 Fully-extended boom	m	65	
		最长主臂+副臂 Fully-extended boom + Jib	m	98	
	起重臂长度 Boom length	基本臂 Base boom	m	13.6	
		最长主臂 Fully-extended boom	m	65	
最长主臂+副臂 Fully-extended boom + Jib		m	99.5		
副臂安装角 Jib offset angle		°	0, 15, 30		
工作速度参数 Working speed	起重臂起臂时间 Boom raising time		s	≤60	
	起重臂全伸时间 Boom fully extended time		s	≤650	
	最大回转速度 Max. slewing speed		r/min	≥1.5	
	支腿收放时间 Outrigger extending and retracting time	水平支腿 Outrigger beam	收 Retracting	s	≤40
			放 Extending	s	≤40
		垂直支腿 Outrigger jack	收 Retracting	s	≤50
			放 Extending	s	≤50
起升速度 (单绳,第四层,空载) Hoisting speed (single line, 4th layer, no load)	主起升机构 Main winch	m/min	≥135		
	副起升机构 Auxiliary winch	m/min	≥90		
噪声 Noise	机外辐射 Exterior noise level		dB ( A )	≤124	
	司机位置处 Noise level at seated position		dB ( A )	≤90	

# 注意事项

## Notes

1. 表中额定总起重量值，是在平整的坚固地面上本起重机能够保证的最大总起重量，包括吊钩和吊具的重量，所以为了估算重物重量，必须减去上述的装置重量。
2. 表中的工作幅度为起吊重物离地时起重物到起重机会转轴线的水平距离，是包括起重臂变形量在内的实际值，因而起吊前应考虑起重臂变形量。
3. 只允许在5级(瞬时风速14.1m/s，风压125N/m<sup>2</sup>)风以下进行作业。
4. 吊重前操作者必须对物体的重量和工作范围了解后选择合适的作业工况，严禁超出表中的数值。幅度及臂长在相邻两个数值之间时，应依据两个数值中较小值确定起重作业。
5. 应按主臂仰角范围作业，即使是空载，也不应使主臂仰角处于范围外，谨防整机倾翻。
6. 表中的主臂长度应要按照每节臂的伸缩要求进行伸出。

1. The total rated loads given in the rated load charts are the maximum lifting capacity when the crane is set up on firm and level ground, which includes the weight of the hook block and slings. The weight of above-mentioned devices should be deducted from the rated lifting load.
2. The working radius shown in the rated load charts is the radius when the load is lifted off the ground, and it is the actual value including loaded boom deflection. Take boom deflection into consideration before beginning a lifting operation.
3. A lifting operation is permissible only when the wind force is below grade 5 (instantaneous wind speed is 14.1 m/s, wind pressure is 125 N/m<sup>2</sup>).
4. Before beginning lifting operation, the operator should know the weight of the load to be lifted and its working range, and then select proper working conditions. Never operate the crane beyond the limit shown in the chart. Use the lower value from the chart when the boom length or working radius is between the range of values.
5. Observe the boom angle limit. Never operate the crane with the boom angle beyond the recommended limit even if a load is not being carried. Otherwise, the crane will tip.
6. The boom should be extended according to the telescoping code shown by digits, which means the percentage of boom sections extended.



本印刷品不属于合同。出于产品不断改进的需要，我们保留对产品型号、参数、配置进行变更的权利，恕不另行通知。图片仅供参考，具体产品以实物为准。图片中产品可能并非标准配置，部分部件可能需要另行购置。办理牌照和上路行驶需遵守当地法规。

This print does not belong to the contract. We reserve the right to modify the design (such as product model, parameters and configuration) without notice for improvement. The pictures are just for reference. The product in the picture may not be standard configuration. Some parts need to be purchased separately. Conform to the local laws for license application and road traveling.